

# ***circle***

*FITNESS*

ALWAYS MOVING FORWARD

---

# ***Owner's Manual***

---

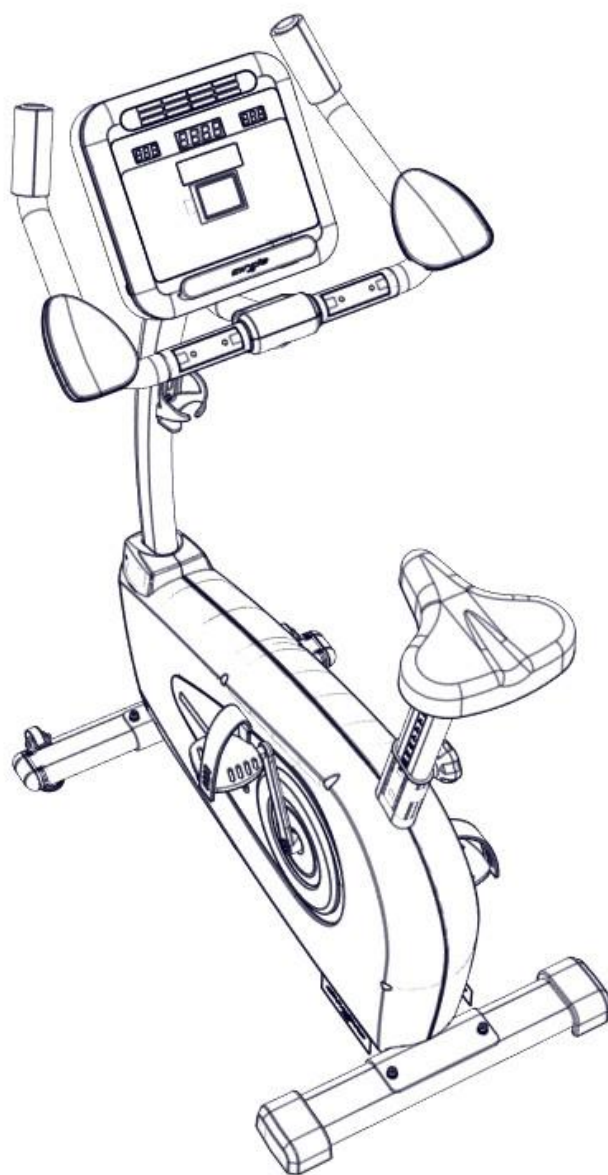

## ***B6 Upright Bike***

---

### ***Assembly***

(The LED Console picture is an example)



# Table of Content

1	SAFETY INFORMATION.....	3
1.1	Important Safety Notes .....	4
1.2	Equipment Label and Serial Number.....	4
1.3	Equipment Placement and Spacing.....	5
1.4	Transportation .....	5
1.5	Power Information .....	6
1.6	CSAFE Port (If Applicable).....	6
2	Specification and Assembly.....	7
2.1	Specification .....	7
2.2	Machine Overview .....	8
2.3	Parts.....	8
2.4	Accessory Pack .....	9
2.5	Assembly Procedures.....	9
2.6	Engineering Mode Settings.....	14
2.7	Operation.....	14
3	Maintenance and Repair .....	15
3.1	Regular Maintenance .....	15
3.2	Warranty Claim .....	16

Dear Customer,

Thank you for selecting Circle Fitness. This product provides an impressive selection of features designed to make your workouts more effective and enjoyable.

For your benefit, read this manual carefully before using the product. If you need the latest version of the owner's manual, you can also visit the official website at <https://www.circlefitness.com/support/> and download it as a dealer.

If you still have any questions after reading the manual, please note the product model and serial number located on the front cover and contact us via email at [service@circlefitness.com](mailto:service@circlefitness.com).

**circle**  
FITNESS



**ALWAYS MOVING FORWARD**

Address: No. 12, Industrial Park 6<sup>th</sup> Road, Taichung 407257, Taiwan

Telephone: +886-4-2359-1009

Fax: +886-4-3505-5801

Email: [service@circlefitness.com](mailto:service@circlefitness.com)

Website: <http://www.circlefitness.com/>

# 1 SAFETY INFORMATION

**IMPORTANT:** Please read all instructions and warnings before assembly and operation.

To assure the correct use of the product, basic safety measures should always be followed including the warnings and cautions listed in this owner's manual.

SAFETY SYMBOLS USED IN THIS MANUAL	
WARNING	Indicates a potentially hazardous situation which, if not avoided, could result in death or serious injury.
CAUTION	Indicates a potentially hazardous situation which, if not avoided, may result in minor / moderate injury to the user / patient or result in damage to the equipment or other property.
DANGER	Indicates a high probability that death, severe bodily injury or major property damage could result.



**IMPORTANT:** It is essential that this equipment is only used indoors in a climate-controlled room.

**WARNING:** Only one person at a time should use this equipment. If dizziness, nausea, chest pains, or any other abnormal symptoms are experienced while using this equipment then please stop the workout at once.

**WARNING:** Always use this equipment on a clear and level surface. Do NOT use outdoors or near water.

**WARNING:** Do NOT drop or insert any object into any openings.

**WARNING:** Do NOT wear loose clothing or jewelry. This equipment has moving parts. Do NOT put fingers or other objects into the moving parts.

**WARNING:** Before using this equipment to exercise, always do stretching exercises first, to properly warm up.

**WARNING:** It is recommended to replace defective components immediately and keep the equipment out of use until repairs have been made by an approved technician.

**WARNING:** Always keep children under age 14 and pets away from the equipment.

**WARNING:** Please consult your physician before starting a workout or a training program. It is best to have your doctor review your training and diet programs first so that they can recommend the best workout routine for you.

**WARNING:** Make sure all screws and nuts are securely tightened before using this equipment. Periodic maintenance is required on all exercise equipment to keep it in good condition.

**WARNING:** Keep your back straight while using this equipment; do not arch your back.

## FCC Compliance (If Applicable)

The components of this equipment have been tested and found to comply with the limits for a Class B digital device, pursuant to part 15 of the FCC Rules. These limits are designed to provide reasonable protection against harmful interference in a residential installation. This equipment generates and can radiate radio frequency energy and, if not installed and used in accordance with the instructions, may cause harmful

interference to radio communications. However, there is no guarantee that interference will not occur in a particular installation. If this equipment does cause harmful interference to radio or television reception, which can be determined by turning the equipment off and on, the user is encouraged to try to correct the interference by one or more of the following measures:

- Reorient or relocate the receiving antenna.
- Increase the separation between the equipment and receiver.
- Connect the equipment into an outlet on a circuit different from that to which the receiver is connected.
- Consult the dealer or an experienced radio/TV technician for help.

## 1.1 Important Safety Notes

**WARNING:** Incorrect/excessive training can cause health injuries. Stop using the equipment when feeling uncomfortable.

**WARNING:** The heart rate sensor is not a medical device. Numerous factors, including the user's movement may affect the accuracy of the heart rate readings. The heart rate sensor is intended only as an exercise aid in determining heart rate trends in general.

**WARNING:** This equipment should not be used by any person weighing more than 300lbs (135 kg).

**WARNING:** Do not hold the handlebars or the console arms when mounting, dismounting, or using the equipment. Use the handlebars for stability only.

**WARNING:** Close supervision is necessary when the equipment is used by, on, or near children, invalids, or disabled persons.

**WARNING:** Use the equipment only for its intended use as described in this manual. Do not use attachments not recommended by the manufacturer.

**WARNING:** Never use the equipment if it has a damaged cord or plug, if it is not working properly, if it has been dropped or damaged, or has been dropped into water. Return the equipment to a service center for examination and repair.

**WARNING:** Never use the equipment with the air openings blocked. Keep the air openings free of lint, hair, and the like.

**WARNING:** Do not use where aerosol (spray) products are being used or where oxygen is being administered.

**WARNING:** This equipment is intended for commercial use.

**CAUTION:** Never touch the moving pedals or cranks with your hands. Also ensure that there are no objects close to the pedals or cranks which could be pulled into it thus causing injury or damaging the unit itself.

**CAUTION:** Repairs on the electrical components in the unit should be conducted by qualified technicians only.



**Waste Disposal:** Products are recyclable. At the end of its useful life please dispose of this article correctly and safely. (Contact your local waste disposal facility)

## 1.2 Equipment Label and Serial Number

The image below shows the equipment label, which is located on the front cover of the machine. The serial number, highlighted by a red circle, consists of one letter followed by nine digits. The first letter represents the equipment type: **T** for treadmills, **E** for elliptical trainers, **R** for recumbent bikes, and **B** for upright bikes. The following nine digits include the manufacturing year and month as part of the serial sequence.



## 1.3 Equipment Placement and Spacing

### Location

Before assembling the unit, verify the chosen site meets the following criteria:

- Area is well lit and well ventilated.
- Surface is structurally sound and properly leveled.
- Place in a location away from direct sunlight. The intense UV light can cause discoloration on the plastics.
- Locate your elliptical in an area with cool temperatures and low humidity.
- Do not install, use, or store the elliptical in an area of high humidity, such as in the vicinity of a steam room, sauna, indoor pool, garage, covered patio, near water or outdoors. Exposure to extensive water vapor, chlorine and/or bromine could adversely affect the electronics as well as other parts of the unit.
- Place the equipment on a level surface. Do NOT place it in any area that will block any vents or air openings.

### Spacing

- Free area for access to the unit and emergency dismount. Minimum clearance is 20 inches (0.5 meters) on the sides of the unit and 79 inches (2 meters) behind the unit.
- Adjacent units may share the free area.
- The minimum spacing recommendations above are based on a combination of the ASTM F2115-19 (U.S.) voluntary standards and EN (European) regulations as of 2019 for access, passage around, and emergency dismount. ASTM standards are voluntary and may not reflect current industry standards. The actual area for access, passage around, and emergency dismount is the responsibility of the facility. The facility should consider the total space requirements for training on each unit, voluntary and industry standards, and any local, state, and federal regulations. Standards and regulations are subject to change at any time.

## 1.4 Transportation

To move the equipment, carefully lift the rear end by pushing down on the 2 front transport wheels. Carefully steer the equipment to another location.

**IMPORTANT:** Be careful when moving this equipment, as it is heavy and awkward. If you do not feel comfortable moving the unit by yourself, please get help.

**CAUTION:** The transport wheels are designed for indoor use only and should not be used to move the unit over rough surfaces such as concrete or asphalt.

## 1.5 Power Information

Product	Line Voltage (V)	Line Frequency (Hz)	Max Current Dissipation (A)	Max Power Dissipation (W)
LED / Touch Model (Self-generation)	N/A	N/A	N/A	N/A

## 1.6 CSAFE Port (If Applicable)

The CSAFE (Communication Specification for Fitness Equipment) port is a standard communication interface designed for fitness equipment, enabling data transmission, power supply, and external device connectivity. The CSAFE port on the Circle Fitness touch screen only provides power for small devices such as wireless audio receivers and transmitters, as shown in the picture in the right.



## 2 Specification and Assembly

### 2.1 Specification

Technical Specifications			
Pedal Spacing	219 mm / 8.6 in		
Resistance Level	16 levels		
Maximum User Weight	135 kg / 300 lbs		
Electrical Specifications			
Power Requirement Self Generation			
Maximum / Minimum Watt ( 60 RPM )	250 /50	Minimum RPM	30
Dimensions & Weight			
Packaged Weight ( lbs/kg )	125 / 57 (LED model as example)		
Equipment Dimensions ( LxWxH ) ( in/mm )	43 x 28 x 58 / 1090 x 700 x 1450		
Packaging Dimensions ( LxWxH ) ( in/mm )	46 x 16 x 30 / 1160 x 399 x 750		
Feature	LED		Touch
Display	7 LED Display		10.1" Touch Screen & 2 LED Display
Programs	Training Course 8 modes : Manual/Rolling-hills / Fat Burn/ Mountain Peaks /Incline / Strength / Interval /Constant Watt Target Training 3 modes : Time/ Distance/Calories HRC 4 modes: Fatburn / Aerobic / Performance / Customize	Training Course 8 modes : Manual/Rolling-hills / Fat Burn/ Mountain Peaks /Incline / Strength / Interval /Constant Watt Target Training 3 modes : Time/ Distance/Calories HRC 4 modes: Fatburn / Aerobic / Performance / Customize	
Heart Rate Detection	Hand Pulse & 5kHz Wireless		
Chest Belt	Optional		
Fan	N/A		

## 2.2 Machine Overview

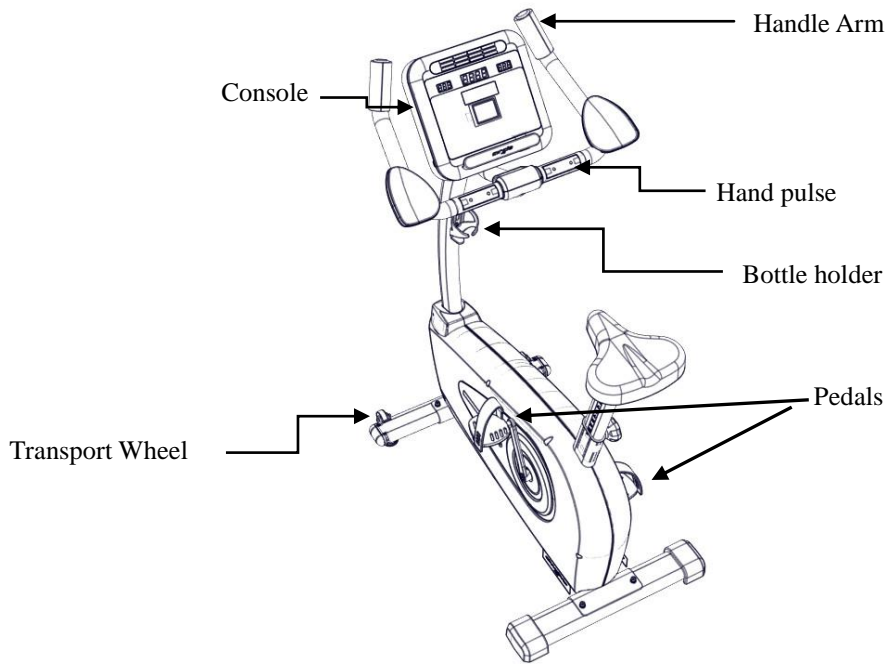

## 2.3 Parts



Console \*1 (LED model as example)

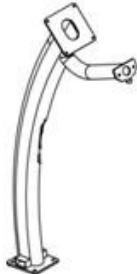

Mast Assembly\*1



Body\*1

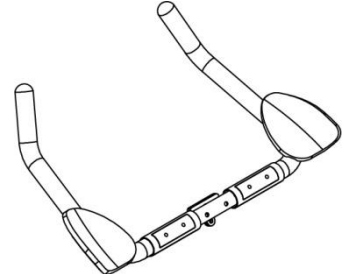

Handle Assembly\*1

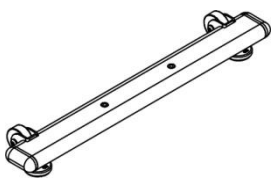

Front Stabilizer\*1

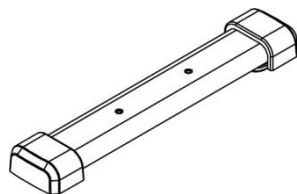

Rear Stabilizer\*1



Bottle Holder\*1

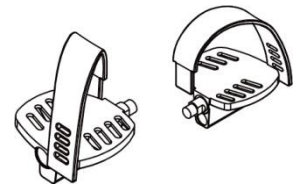

Left / Right Pedal\*1

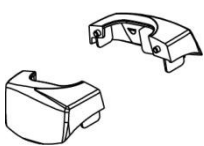

Mast Trim Cover Left / Right\*1



Upper / Lower Handle Assembly Trim Cover\*1



Accessory Pack\*1

## 2.4 Accessory Pack

### Required for Step 4 (Handle Assembly)



Hex Socket Cap Screw  
(M8x20mm\*1)



Hex Socket Cap Screw  
(M8x65mm\*2)



Curved Washer  
(M8\*2)

### Required for Step 5 (Handle Assembly Trim Cover)



Philips Screw  
(M4x20mm\*2)

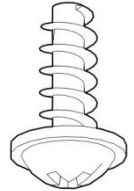

Philips Screw  
(M4x12mm\*2)

### Required for Step 7 (Console)



Philips Screw (M5x12mm\*4)

### Others



L-shaped Hex Wrench with Screw  
Driver 6-95mm\*1



Wrench 15-158mm\*1

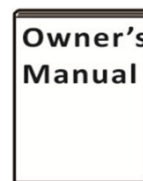

Owner's Manual\*1

## 2.5 Assembly Procedures

### Carton Removal

Prior to opening the shipping box, first you need to cut the fiberglass straps from around the wrapped carton and remove the upper carton cover upward. Before beginning assembly, it is recommended to place a protective mat under the packaging and parts to prevent scratches. **Note: Due to the weight of the equipment, it is strongly advised to have a second person assist with the assembly.**

### Assembly

Step 1: Attach the front and rear stabilizers to the body.

- As shown in the image below, use a hex wrench to secure the front stabilizer to the body using the two pre-installed hex socket cap screws (M8 x 20mm), two M8 spring washers, and two M8 flat washers.
- Repeat the same process for the rear stabilizer, using the pre-installed screws and washers to attach it to the body.

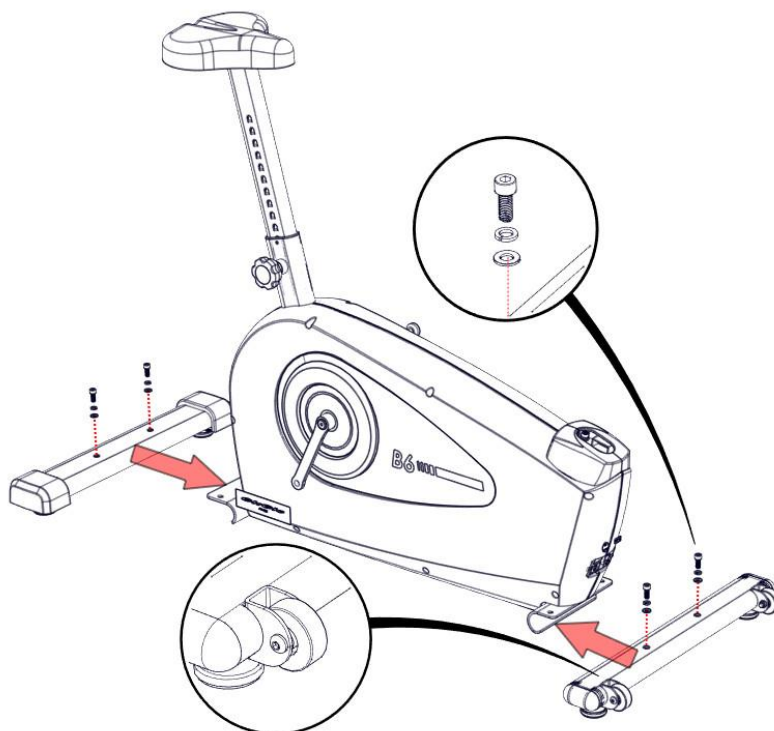

Step 2: Install the pedals. Use a wrench to install the right and left pedal assemblies onto the corresponding cranks.

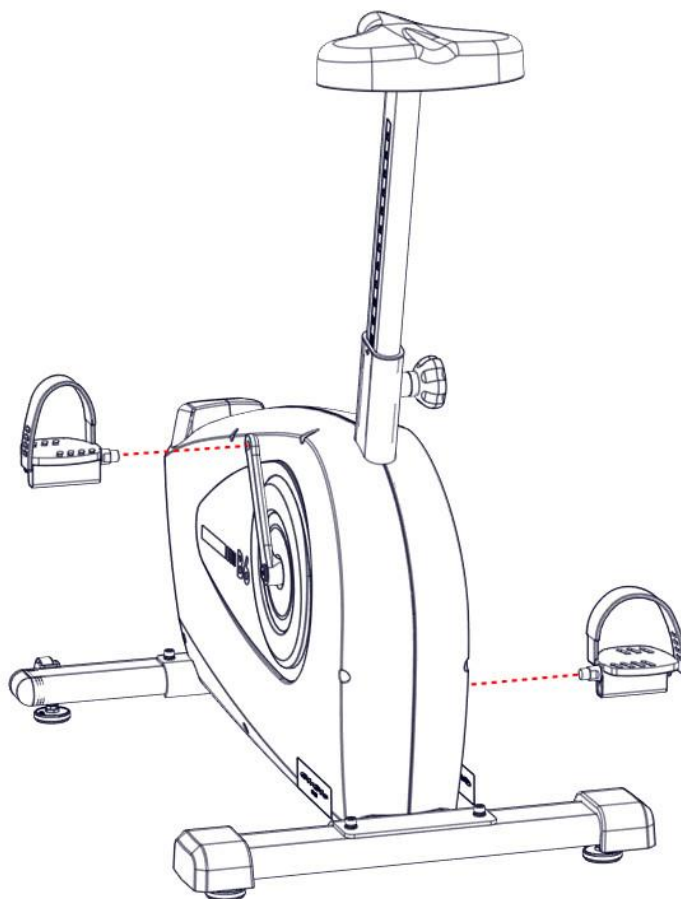

Step 3: Route the wires through the mast, then attach the mast to the body.

- As indicated by the long arrow, use the guide wire inside the mast to pull the wires (listed in Step 7) from the bottom of the mast to the top.
- As indicated by arrow 1, use a hex wrench to secure the mast to the body using the four pre-installed hex socket cap screws (M8 x 20mm), four M8 spring washers, and four M8 flat washers.
- As indicated by arrow 2, install the left and right mast trim covers.

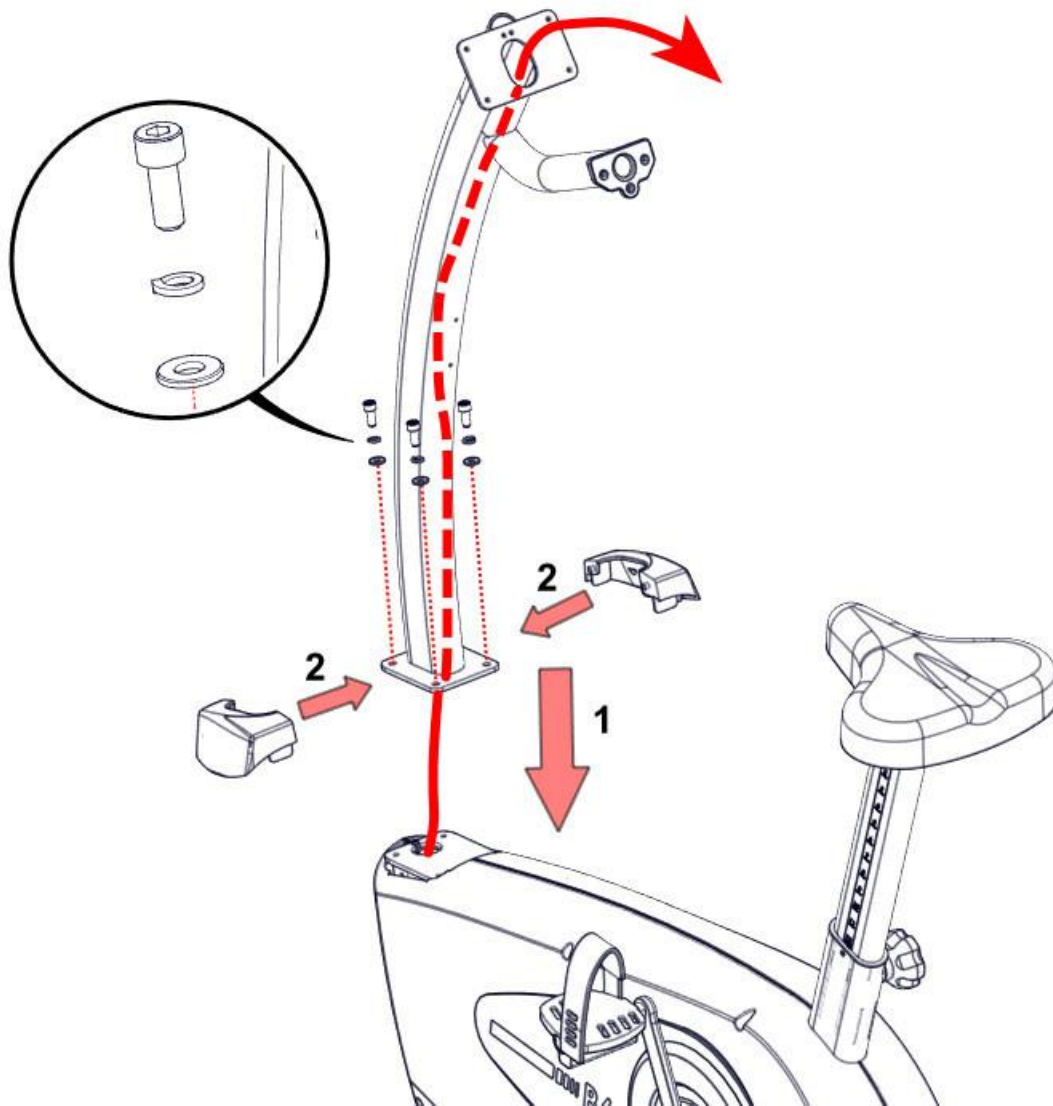

Step 4: Connect the handle wires and secure the handle assembly

- Refer to the table below to connect the wires from the mast to the corresponding wires from the handle assembly.
- Use a hex wrench to secure the handle assembly to the mast using two hex socket cap screws (M8 x 65mm), two M8 curved washers, and one hex socket cap screw (M8 x 20mm) from the accessory pack.

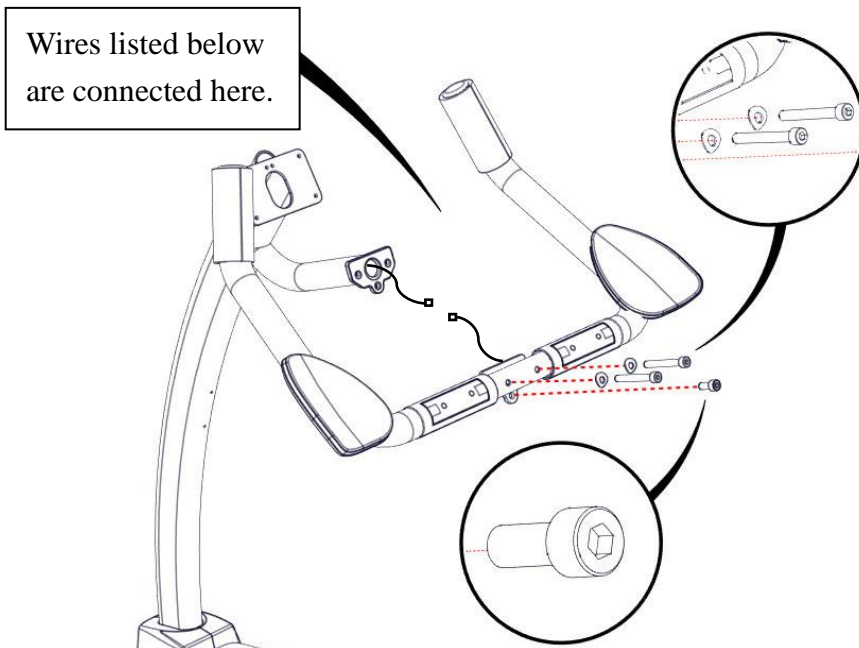

	<p>Hand Pulse Wire (4 pin connector *1)</p>
---	---

Step 5: Use a Phillips screwdriver to attach the lower handle assembly trim cover to the handle assembly with the two Phillips screws (M4 x 20mm) for metal parts from the accessory pack. Then assemble the upper and lower handle assembly trim covers with two Phillips screws (M4 x 12mm) for plastic parts from the accessory pack.

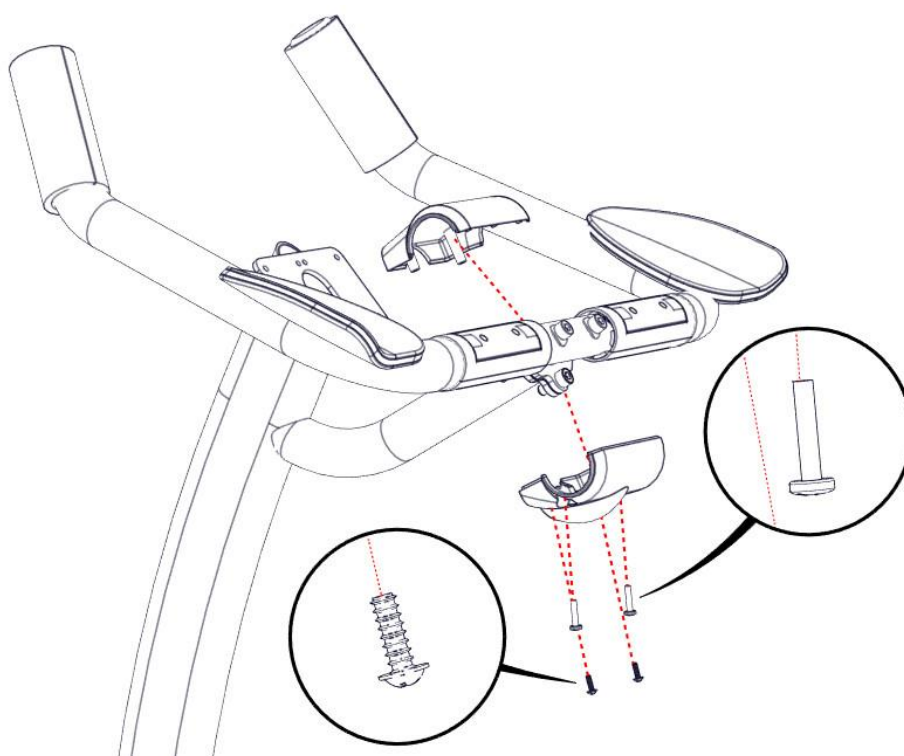

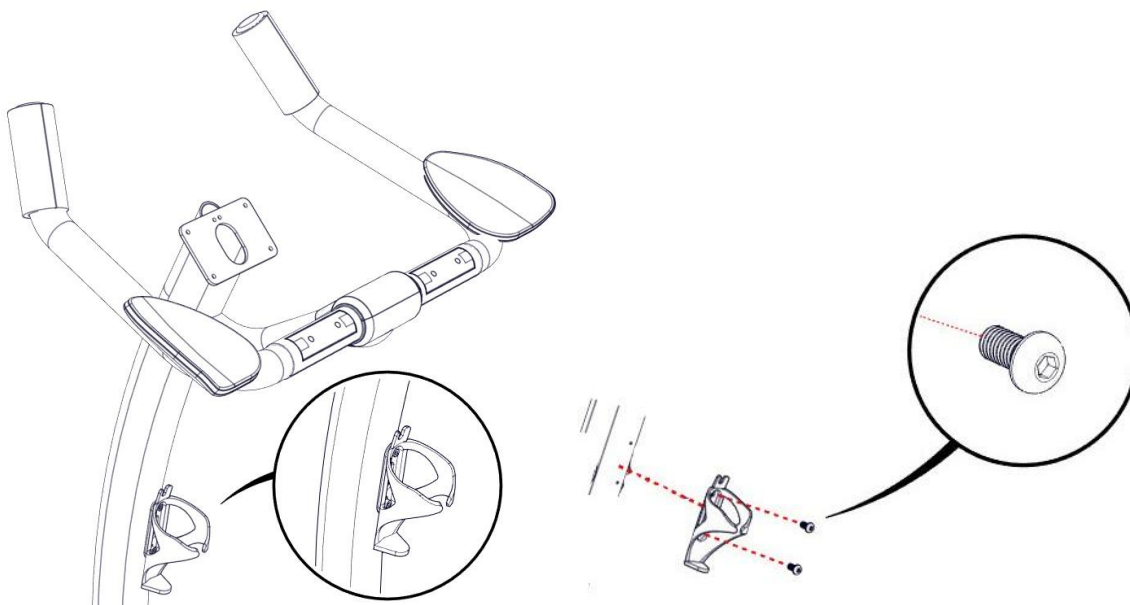

Step 6: Use a hex wrench to attach the bottle holder to the mast with two hex socket button head screws from the package of bottle holder.

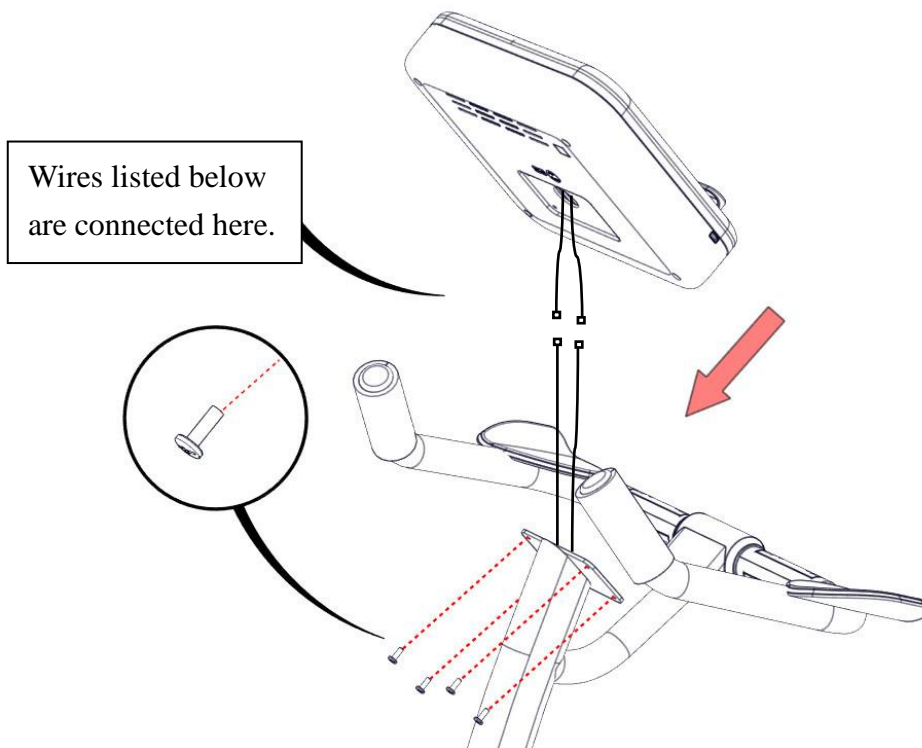

Step 7: Install the console onto the mast.

- Connect the wires pulled up through the mast to the corresponding connectors extending from the bottom of the console, according to the table below.
- Use a Phillips screwdriver to mount the console onto the mast with four Phillips screws (M5x12mm) pre-installed on the console. **Note: Be careful not to pinch or damage the wires during installation.**



	<p>Console Wire</p>
	<p>Hand Pulse Wire (4 pin connector *1)</p>

## 2.6 Engineering Mode Settings

Please refer to the owner's manual of the console for details on the [Engineering Mode Settings] section.

## 2.7 Operation

### Test Operation

Follow the instructions below to test the full resistance of the elliptical trainer and ensure proper functionality:

- Step onto the pedals and begin pedaling while holding the handles for stability.
- Check if the console screen lights up normally.(Applicable to self-generation models)
- Test the full resistance range in sequence:
  - A. Press the "Resistance Increase (+)" button until the equipment reaches the maximum resistance level.
  - B. Press the "Resistance Decrease (-)" button until the equipment reaches the minimum resistance level.
- When the pedals come to a complete stop, hold the handles securely before stepping off the machine.

### Heart Rate Measurement

Place both palms directly on the heart rate sensor handles and maintain contact with the sensor area for an accurate heart rate measurement. After approximately 5 seconds, your heart rate reading will appear on the screen. Avoid gripping the sensor handles too tightly - gently rest your hands with moderate pressure. If you see an unusually high or unstable heart rate reading, allow the display to reset to zero before testing again.

Do not operate the heart rate sensors while exercising; it is recommended to hold the sensor handles only when you need to check your heart rate.



### Chest Belt (Optional)

Position the chest belt just under your pectoral muscles or sports bra. **CAUTION:** To read an accurate and consistent reading, the chest belt should be fairly tight around the torso and just tighter than is comfortable.

### Consult Your Physician Immediately

- **WARNING:** Consult your physician before starting any exercise program, especially if you are over 35 years old or have existing health conditions.
- Read all instructions before using the equipment.
- The company is not responsible for any personal injury or property damage resulting from the use of this equipment.

## Exercise Recommendations

- **Frequency:** It is recommended to exercise 3 to 4 times per week to improve cardiovascular and muscular health.
- **Intensity:** Heart rate reflects exercise intensity and should be determined by a physician, reaching a level that strengthens the heart and improves the cardiovascular system.
- **Intervals:** Continuous exercise helps train the heart, lungs, and muscles. Beginners should maintain a steady pace for 2 to 3 minutes before checking their heart rate.

## Handling Abnormalities

If the equipment malfunctions, immediately turn off the power and unplug the device. Contact your dealer for assistance and do not attempt to disassemble the equipment yourself, as this may pose a safety risk.

# 3 Maintenance and Repair

## 3.1 Regular Maintenance

**WARNING: Always unplug the power cord before cleaning, lubricating, or performing any maintenance work.**

The safety of the equipment can be maintained only if it is examined regularly for damage or wear. If maintenance is required, keep the equipment out of use until defective parts are repaired or replaced. The following preventive maintenance tips will keep the machine operating at peak performance:

- Store in a cool, dry place.
- Keep the screen free of fingerprints and sweat residue buildup.
- Avoid pressing the control panel with long fingernails to prevent scratches; use your fingertip instead.
- Clean the equipment surface with a 100% cotton cloth slightly dampened with water or a mild liquid cleaner. Avoid using paper towels or any abrasive materials.
- Do not use cleaners containing ammonia or acidic ingredients.

### Preventive Maintenance Schedule (W for Wipe, V for Visual Inspection)

Item	Parts	Daily	Weekly	Monthly	Quarterly	Semi-Annually
1	Console screws					V
2	Body	W		V		
3	Pedal and cranks	W		V		
4	Console overlay	W		V		
5	Heart rate handle	W	V			
6	Drive belts and groves				V	
7	Seat height adjuster				V	
8	Bottle holder	W				
9	All cosmetic plastics	W				

## 3.2 Warranty Claim

Please first visit the official website at <https://www.circlefitness.com/support/> to download the service manual as a dealer for troubleshooting. If the issue is not resolved, please go to <http://goo.gl/forms/OplmbWO9kXHJuDYc2> to submit warranty claims. Please provide information as mentioned below and upload your pictures/video clips. Automatic confirmation email will be sent out via [warranty.claim259@gmail.com](mailto:warranty.claim259@gmail.com) so please make sure this email address is not blocked by your server or email software.

- Vendor's code
- Your email address
- Your name
- Your phone number
- Model description: Please refer to the "Model" field on the equipment label and enter the appropriate model, such as M8, M8 EPlus, M8S, M8T, E8, E8T, E8S, E8 EPlus, B8, B8 EPlus, B8T, or B8S. Only one model can be submitted at a time.
- Serial Number: Please refer to the "Serial Number" field on the equipment label. The serial number consists of one letter followed by nine digits. The first letter represents the equipment type: **T** for treadmills, **E** for elliptical trainers, **R** for recumbent bikes, and **B** for upright bikes. The following nine digits include the manufacturing year and month as part of the serial sequence. You may fill in multiple serial numbers if you submit a warranty claim for the same model.

- Problem description:

Example 1: Incline window showed "Err". All functions of the treadmill are normal except the lift motor. Our engineer has made diagnostics according to the document "Engineering Manual - Trouble Shooting". Also there is a loud noise while pressing the "UP" button. So, he considers the lift motor to be faulty.

Example 2: Display problem: One LED segment is always off.

- Issue solved or not? Solved/ Not solved yet/ others
- Requested Part Name/Number
- Link to the Folder of Pictures/Video Clips: Photos of **warranty labels** are essential for warranty claims on electronics like console, lift motor, inverter, generators and etc.
- End Customer Site Description and Contact
- Reported Failure Date
- Preferred Shipping Method
- Comments: Please leave comments for this issue here if you have any



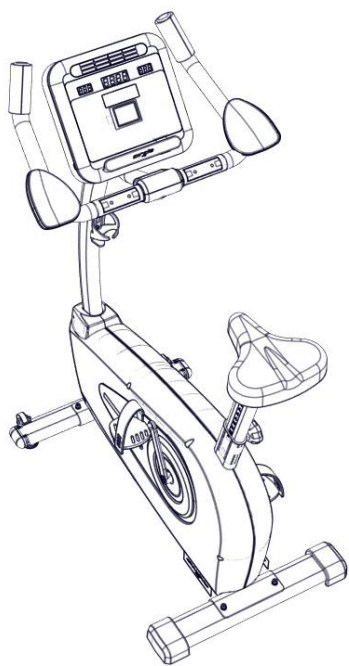

***circle***  
*FITNESS*

---

ALWAYS MOVING FORWARD



[www.circlefitness.com](http://www.circlefitness.com)