

# *circle*

FITNESS

ALWAYS MOVING FORWARD

---

# *Owner's Manual*

---

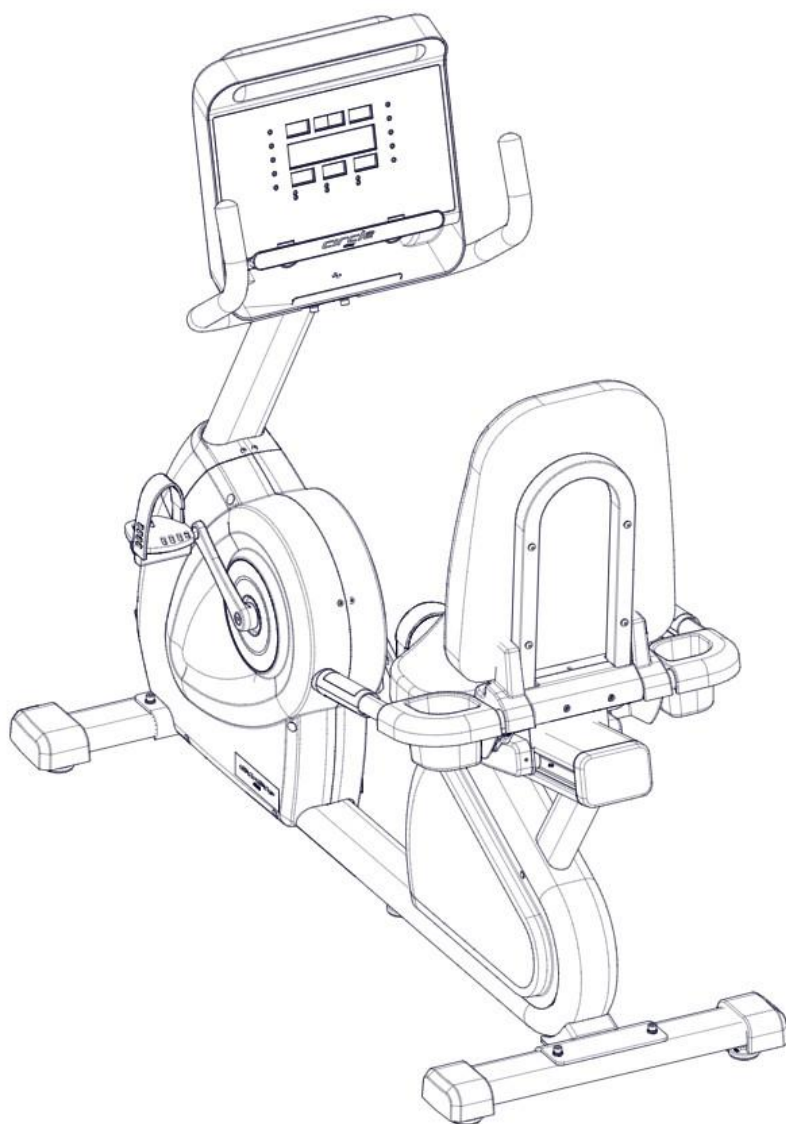

## *R8 Recumbent Bike*

---

## *Assembly*

(The LED Console picture is an example)



# Table of Content

1	SAFETY INFORMATION .....	1
1.1	Important Safety Notes .....	2
1.2	Equipment Label and Serial Number.....	3
1.3	Equipment Placement and Spacing.....	3
1.4	Transportation .....	4
1.5	Grounding Instructions and Power Requirements .....	4
1.6	Proper Power Cord Connection and Placement.....	4
1.7	Facility Power Requirements .....	5
1.8	Receptacle Requirements .....	5
1.9	Actual vs. Maximum Current Rating.....	6
1.10	Television Connection Requirements (If Applicable).....	6
1.11	CSAFE Port (If Applicable).....	7
1.12	Internet Requirements (If Applicable) .....	7
1.13	Installation Checklist .....	8
2	Specification and Assembly.....	9
2.1	Specification .....	9
2.2	Machine Overview .....	10
2.3	Parts.....	10
2.4	Accessory Pack .....	11
2.5	Assembly Procedure .....	13
2.6	Engineering Mode Settings.....	19
2.7	Operation.....	19
3	Maintenance and Repair .....	20
3.1	Regular Maintenance .....	20
3.2	Warranty Claim .....	21

Dear Customer,

Thank you for selecting Circle Fitness. This product provides an impressive selection of features designed to make your workouts more effective and enjoyable.

For your benefit, read this manual carefully before using the product. If you need the latest version of the owner's manual, you can also visit the official website at <https://www.circlefitness.com/support/> and download it as a dealer.

If you still have any questions after reading the manual, please note the product model and serial number located on the front cover and contact us via email at [service@circlefitness.com](mailto:service@circlefitness.com).

**circle**  
FITNESS



**ALWAYS MOVING FORWARD**

Address: No. 12, Industrial Park 6<sup>th</sup> Road, Taichung 407257, Taiwan

Telephone: +886-4-2359-1009

Fax: +886-4-3505-5801

Email: [service@circlefitness.com](mailto:service@circlefitness.com)

Website: <http://www.circlefitness.com/>

# 1 SAFETY INFORMATION

**IMPORTANT:** Please read all instructions and warnings before assembly and operation.

To assure the correct use of the product, basic safety measures should always be followed including the warnings and cautions listed in this owner's manual.

SAFETY SYMBOLS USED IN THIS MANUAL	
WARNING	Indicates a potentially hazardous situation which, if not avoided, could result in death or serious injury.
CAUTION	Indicates a potentially hazardous situation which, if not avoided, may result in minor / moderate injury to the user / patient or result in damage to the equipment or other property.
DANGER	Indicates a high probability that death, severe bodily injury or major property damage could result.



**IMPORTANT:** It is essential that this equipment is only used indoors in a climate-controlled room.

**WARNING:** Only one person at a time should use this equipment. If dizziness, nausea, chest pains, or any other abnormal symptoms are experienced while using this equipment then please stop the workout at once.

**WARNING:** Always use this equipment on a clear and level surface. Do NOT use outdoors or near water.

**WARNING:** Do NOT drop or insert any object into any openings.

**WARNING:** Do NOT wear loose clothing or jewelry. This equipment has moving parts. Do NOT put fingers or other objects into the moving parts.

**WARNING:** Before using this equipment to exercise, always do stretching exercises first, to properly warm up.

**WARNING:** It is recommended to replace defective components immediately and keep the equipment out of use until repairs have been made by an approved technician.

**WARNING:** Always keep children under age 14 and pets away from the equipment.

**WARNING:** Please consult your physician before starting a workout or a training program. It is best to have your doctor review your training and diet programs first so that they can recommend the best workout routine for you.

**WARNING:** Make sure all screws and nuts are securely tightened before using this equipment. Periodic maintenance is required on all exercise equipment to keep it in good condition.

**WARNING:** Keep your back straight while using this equipment; do not arch your back.

## FCC Compliance (If Applicable)

The components of this equipment have been tested and found to comply with the limits for a Class B digital device, pursuant to part 15 of the FCC Rules. These limits are designed to provide reasonable protection against harmful interference in a residential installation. This equipment generates and can radiate radio frequency energy and, if not installed and used in accordance with the instructions, may cause harmful

interference to radio communications. However, there is no guarantee that interference will not occur in a particular installation. If this equipment does cause harmful interference to radio or television reception, which can be determined by turning the equipment off and on, the user is encouraged to try to correct the interference by one or more of the following measures:

- Reorient or relocate the receiving antenna.
- Increase the separation between the equipment and receiver.
- Connect the equipment into an outlet on a circuit different from that to which the receiver is connected.
- Consult the dealer or an experienced radio/TV technician for help.

## 1.1 Important Safety Notes

**WARNING:** Incorrect/excessive training can cause health injuries. Stop using the equipment when feeling uncomfortable.

**WARNING:** The heart rate sensor is not a medical device. Numerous factors, including the user's movement may affect the accuracy of the heart rate readings. The heart rate sensor is intended only as an exercise aid in determining heart rate trends in general.

**WARNING:** This equipment should not be used by any person weighing more than 400lbs (180 kg).

**WARNING:** Do not hold the handlebars or the console arms when mounting, dismounting, or using the equipment. Use the handlebars for stability only.

**WARNING:** Do not leave equipment unattended when plugged in. Turn all controls to OFF and unplug from outlet when not in use or before removing / replacing parts.

**WARNING:** Close supervision is necessary when the equipment is used by, on, or near children, invalids, or disabled persons.

**WARNING:** Use the equipment only for its intended use as described in this manual. Do not use attachments not recommended by the manufacturer.

**WARNING:** Never use the equipment if it has a damaged cord or plug, if it is not working properly, if it has been dropped or damaged, or has been dropped into water. Return the equipment to a service center for examination and repair.

**WARNING:** Do not carry the equipment by the supply cord or use the cord as a handle.

**WARNING:** Keep the cord away from heated surfaces.

**WARNING:** Never use the equipment with the air openings blocked. Keep the air openings free of lint, hair, and the like.

**WARNING:** Do not use where aerosol (spray) products are being used or where oxygen is being administered.

**WARNING:** Only connect the equipment to a properly grounded outlet. See Grounding Instructions.

**WARNING:** This equipment is intended for commercial use.

**CAUTION:** Ensure that the power cable is not pinched and that no one can trip over it.

**CAUTION:** Never touch the moving seat slider tracks, pedals or cranks with your hands. Also ensure that there are no objects close to the pedals or cranks which could be pulled into it thus causing injury or damaging the unit itself.

**CAUTION:** Repairs on the electrical components in the unit should be conducted by qualified technicians only.

**DANGER:** To reduce the risk of electric shock, always unplug this appliance from the electric outlet at once

after using or before cleaning.



**Waste Disposal:** Products are recyclable. At the end of its useful life please dispose of this article correctly and safely. (Contact your local waste disposal facility)

## 1.2 Equipment Label and Serial Number

The image below shows the equipment label, which is located on the front cover of the machine. The serial number, highlighted by a red circle, consists of one letter followed by nine digits. The first letter represents the equipment type: **T** for treadmills, **E** for elliptical trainers, **R** for recumbent bikes, and **B** for upright bikes. The following nine digits include the manufacturing year and month as part of the serial sequence.



## 1.3 Equipment Placement and Spacing

### Location

Before assembling the unit, verify the chosen site meets the following criteria:

- Area is well lit and well ventilated.
- Surface is structurally sound and properly leveled.
- Place in a location away from direct sunlight. The intense UV light can cause discoloration on the plastics.
- Locate your elliptical in an area with cool temperatures and low humidity.
- Do not install, use, or store the elliptical in an area of high humidity, such as in the vicinity of a steam room, sauna, indoor pool, garage, covered patio, near water or outdoors. Exposure to extensive water vapor, chlorine and/or bromine could adversely affect the electronics as well as other parts of the unit.
- Place the equipment on a level surface. Do NOT place it in any area that will block any vents or air openings.

### Spacing

- Free area for access to the unit and emergency dismount. Minimum clearance is 20 inches (0.5 meters) on the sides of the unit and 79 inches (2 meters) behind the unit.
- Adjacent units may share the free area.
- The minimum spacing recommendations above are based on a combination of the ASTM F2115-19 (U.S.) voluntary standards and EN (European) regulations as of 2019 for access, passage around, and emergency dismount. ASTM standards are voluntary and may not reflect current industry standards. The actual area for access, passage around, and emergency dismount is the responsibility of the facility. The facility should consider the total space requirements for training on each unit, voluntary and industry standards, and any local, state, and federal regulations. Standards and regulations are subject to change at any time.

## 1.4 Transportation

To move the equipment, carefully lift the rear end by pushing down on the 2 front transport wheels. Carefully steer the equipment to another location.

**IMPORTANT:** Be careful when moving this equipment, as it is heavy and awkward. If you do not feel comfortable moving the unit by yourself, please get help.

**CAUTION:** The transport wheels are designed for indoor use only and should not be used to move the unit over rough surfaces such as concrete or asphalt.

## 1.5 Grounding Instructions and Power Requirements

**All building electrical power and wiring shall comply with the currently adopted electrical codes in your area.**

**WARNING:** Failure to follow these specifications can cause damage to your product and can void the warranty.

- All power outlets must be functional the day of delivery/assembly of the product. The client is responsible for any added installation charges associated with return visits.
- Electrical supply may fluctuate in your area. To ensure the stable performance of the product, we require the following wiring gauges be used based on the distance between the unit and the panel:
  - 100 ft. (30.5 meter) or less = 12 AWG
  - 101 ft. – 125 ft. (30.8 - 38.1 meter) = 10 AWG
  - 126 ft. – 150 ft. (38.4 - 45.7 meter) = 8 AWG
  - An electrical power supply run over 150 ft. (45.7 meter) is not recommended
  - Circle Fitness recommends circuit breakers designed to manage inductive loads. An example is the QO-HM120 breaker.

### Power Information

Product	Line Voltage (V)	Line Frequency (Hz)	Max Current Dissipation (A)	Max Power Dissipation (W)
EPlus / Sport Model	110 / 220	50~60	5 (110V model) 2.5 (220V model)	600
LED / Touch Model (Self-generation)	N/A	N/A	N/A	N/A

## 1.6 Proper Power Cord Connection and Placement

- Do not use extension cords, modify the power cord or the plug provided with the equipment.
- Do not use an adapter to connect the plug to an ungrounded two-prong outlet. If a properly grounded outlet is not available, have one installed by a qualified electrician.
- Keep the power cord away from heated surfaces.
- Do not run the power cord across an area where it may become a tripping hazard or have the potential to receive damage from objects rolling over the cord.



Attention: Obtain the assistance of a licensed electrician before installing, modifying, or servicing any part of the electrical power supply for your equipment.

## 1.7 Facility Power Requirements

### Branch Circuit

- When designing a facility or installing new Circle Fitness equipment into an existing facility, it is necessary to have the correct electrical power provisions. Without a proper electrical supply, the equipment will not run in a safe and proper manner.
- Dedicated outlets must not share line, neutral, or ground conductors with other outlets. This means that a single breaker, one hot wire, one neutral wire, and one ground wire are connected from the panel to a single electrical load. All circuits for equipments **SHOULD NOT SHARE A NEUTRAL OR A GROUND**. Each neutral wire and each ground wire should be tied back to the panel.

### Isolated Circuit

The term "Isolated" has been misused in the past to describe an individual branch circuit. An Isolated circuit describes an electrical power circuit that is isolated from the rest of the electrical power in the building through a separate transformer. Circle Fitness equipment does not require isolated circuits. This is usually used only for equipment that is extremely sensitive to electrical noise in the power lines.

### GFCI Outlet

The elliptical should not be connected to a GFCI circuit as the equipment needs a steady circuit flow and power shortages could lead to damaging components of your equipment. The equipment can cause nuisance tripping of GFCI's, which can result in damaged part(s) on the equipment. For an uninterrupted experience, do not use with GFCI outlets. If no suitable outlet is available, contact an electrician.



### NEC (National Electric Code)

The National Electrical Code (NEC), or NFPA 70, is a U.S. standard for the safe installation of electrical wiring and equipment. It is part of the National Fire Codes series published by the National Fire Protection Association (NFPA). "National Electrical Code" and "NEC" are registered trademarks of the NFPA. While the NEC is not itself a U.S. law, NEC use is commonly mandated by state or local law, as well as in many jurisdictions outside of the United States. The NEC codifies the requirements for safe electrical installations into a single, standardized source.

## 1.8 Receptacle Requirements

The receptacle, for general purpose use, should be both grounded and polarized. The following is an example of NEMA 5-20P for standard socket configurations:

- A slot for a center- line- rounded pin: There must be a slot for a center- line- rounded pin ( GROUND ) connected to a common grounding conductor.

- Blade-shaped slots of different sizes: The two blade-shaped slots ( NEUTRAL and HOT/LINE ) must be of different sizes, to prevent ungrounded (2-wire) devices which use “neutral” as their only grounding from being misconnected.

Wall Receptacle

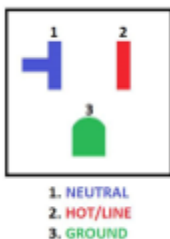

Power Cord Plug



The power cord supplied with the equipment comes with a region-specific plug and it must correspond to the receptacle that complies with local regulations. The figure below shows the international power receptacle guide.

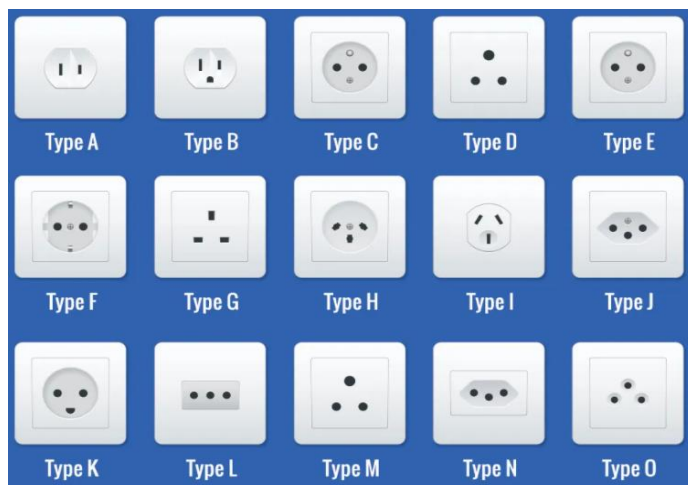

### 1.9 Actual vs. Maximum Current Rating

Generally speaking, a 15-amp fuse or circuit breaker is not actually intended to routinely carry 15 amps of power. In fact, a given circuit may only carry up to 80% of its maximum-rated capacity, with the remaining 20% intended as a safety margin. The following table shows maximum capacity versus rated capacity.

Maximum Rated Circuit Capacity	Actual Rated Circuit Capacity
10 amps	8 amps
15 amps	12 amps
20 amps	16 amps

### 1.10 Television Connection Requirements (If Applicable)

For live television on Circle Fitness equipment, coaxial cable must be run to the machine. All cabling internal to the fitness equipment will be supplied by Circle Fitness. All other cabling necessary to run from a TV or internet source to the Circle Fitness cardio product must be provided by the facility.

#### TV Cabling Requirements

The Circle Fitness touch screen equipped with a U.S. TV reception module supports the following three different types of TV signals used in the United States:

- NTSC (analog un-coded): old air broadcast, and un-coded cable TV
- ATSC (digital un-coded): used in current over-the-air broadcasts, and some un-coded cable TV
- QAM (digital cable): used in current un-coded and coded cable TV

In the US, some cable TV companies offer a basic package that does not require a set-top box – that signal acquired with any cable-ready TV. This type of service works best with Circle Fitness touch screen consoles as it uses either NTSC or ATSC/QAM Clear. The un-coded signal lets the facility simply connect the coaxial cable (RG6) to the connector on the Circle Fitness equipment and scan for channels.

Based on customer requirements, the Circle Fitness touch screen TV reception module can also support various digital TV broadcast standards used worldwide (ATSC, DVB-C, DVB-T, DVB-T2, ISDB-T, DTMB). However, the signal source must meet the following requirements:

- Signal must be delivered to the equipment unencrypted.
- Coaxial cable must be a quad-shielded RG6 cable with an F-Type compression fitting.
- Splitters or taps are acceptable for distributing signal, provided that the signal strength delivered to the equipment meets the required levels
- Confirm with your cable TV provider that the signal strength at each machine is adequate

### 1.11 CSAFE Port (If Applicable)

The CSAFE (Communication Specification for Fitness Equipment) port is a standard communication interface designed for fitness equipment, enabling data transmission, power supply, and external device connectivity. The CSAFE port on the Circle Fitness touch screen only provides power for small devices such as wireless audio receivers and transmitters, as shown in the picture in the right.



### 1.12 Internet Requirements (If Applicable)

As shown below, a download speed of at least 10Mbps is required to connect four Circle Fitness touch screens to the internet:

- Wireless Internet: A router/gateway and wireless access points ( AP ) must be installed. And it supports IEEE 802.11 ac/a/b/g/n Wi-Fi standards.
- Wired Internet: A router/gateway, CAT5e or CAT6 cables with RJ45 connectors are required.

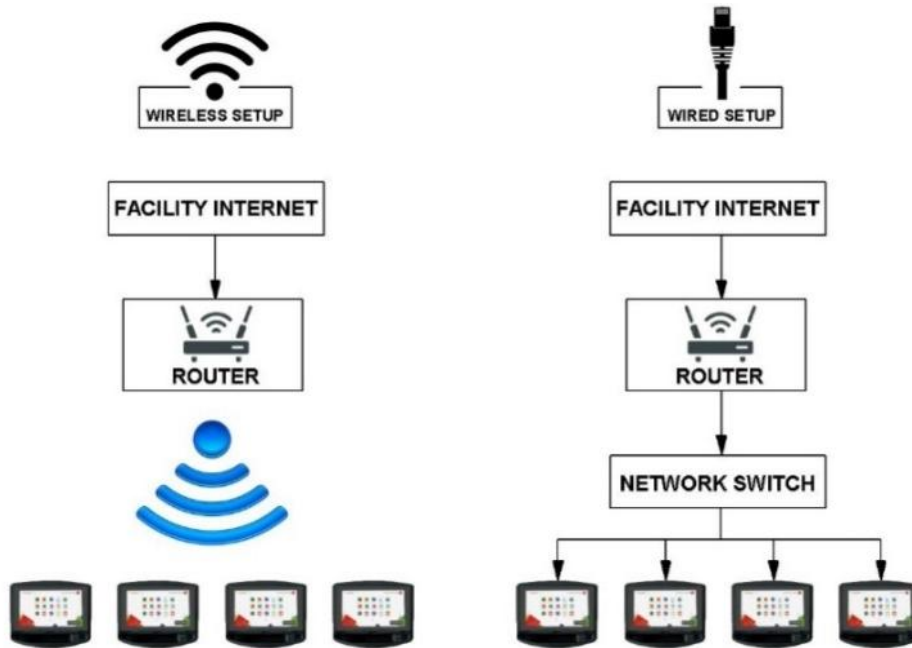

**SAVE THESE INSTRUCTIONS FOR FUTURE REFERENCE**

**1.13 Installation Checklist**

We created this basic installation guide to help you in the installation process of internet and/or TV to your Circle Fitness console. Here is a final installation checklist to help make the process run smoother.

<b>POWER REQUIREMENTS</b>	<b>COMPLETED</b>	<b>N/A</b>
Region-specific receptacles are ready		
Power supplied for Internet router/gateway		
<b>CABLE TELEVISION REQUIREMENTS</b>	<b>COMPLETED</b>	<b>N/A</b>
Confirm Television solution choice for equipment		
Coaxial cable runs to each machine		
Cat5e or Cat6 cable run to each machine (IPTV)		
<b>INTERNET</b>	<b>COMPLETED</b>	<b>N/A</b>
Sufficient bandwidth confirmed for the equipment (at least 10Mbps for four consoles)		
Wireless Network connected		
<b>CHECKLIST ACKNOWLEDGEMENT</b>		

Circle Fitness Representative: \_\_\_\_\_ Date: \_\_\_\_\_

Customer Representative: \_\_\_\_\_ Date: \_\_\_\_\_

## 2 Specification and Assembly

### 2.1 Specification

Technical Specifications				
Pedal Spacing (Q Factor)		240 mm / 9.5 in		
Resistance Level		25 Levels		
Maximum User Weight		182 kg / 400 lbs		
Electrical Specifications				
Power Requirement	LED / Touch	Self Generation		
	Sport / EPlus	110V±10% / 220V±10% (50/60Hz)		
Maximum / Minimum Watt ( 60 RPM )		400 /40	Minimum RPM	30 (LED/Touch) / 10 (Sport/EPlus)
Dimensions & Weight				
Packaged Weight ( lbs/kg )		210 / 95 (EPlus model as example)		
Equipment Dimensions ( LxWxH ) ( in/mm )		67 x 25 x 56 / 1680 x 630 x 1420		
Packaging Dimensions ( LxWxH ) ( in/mm )		66 x 15 x 29 / 1668 x 376 x 730		
Feature	LED	Touch	Sport	EPlus
Display	7 LED Display	10.1" Touch Screen & 2 LED Display	8" Touch Screen & 2 LED Display	15.6" Touch Screen
Programs	10 modes : Target/Rolling/ Valley / Fat Burn / Ramp/ Strength/ Interval/ Random / HRC / Constant Watt	Training Course 8 modes : Manual/Rolling-hills / Fat Burn/ Mountain Peaks / Strength / Interval /Incline/Constant Watt Target Training 3 modes : Time/ Distance/Calories HRC 4 modes: Fatburn / Aerobic / Performance / Customize	Training Course 9 modes: Manual / Target / Rolling-hills / Fat Burn / Mountain Peaks / Strength / Interval / Incline / Constant Watt HRC 4 modes : Fatburn / Aerobic / Performance / Customize	Training Course 9 modes : Manual / Target / Rolling - hills / Fat Burn / Mountain Peaks / Strength / Interval / Incline / Constant Watt HRC 4 modes : Fatburn / Aerobic / Performance / Customize Virtual Go:10 Trails
Heart Rate Detection	Hand Pulse & 5kHz Wireless	Hand Pulse & 5kHz Wireless	Hand Pulse & 5kHz Wireless	Hand Pulse & 5kHz Wireless, Bluetooth and ANT+
Chest Belt	Optional	Optional	Optional	Optional
Fan	N/A	N/A	Optional	Yes

## 2.2 Machine Overview

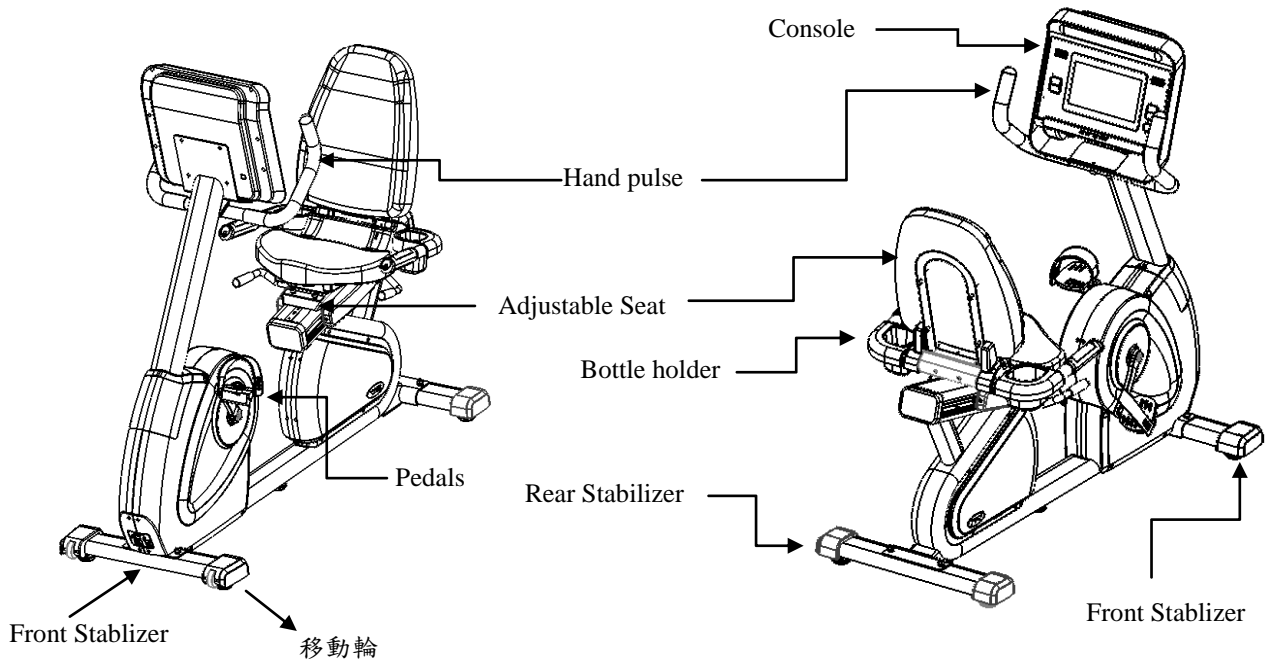

## 2.3 Parts

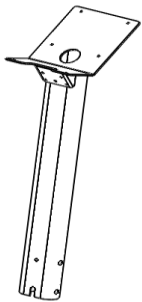

Mast\*1

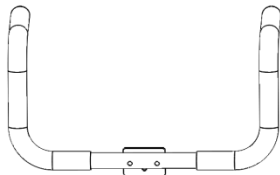

Upper Handle Assembly \*1

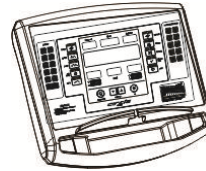

Console\*1

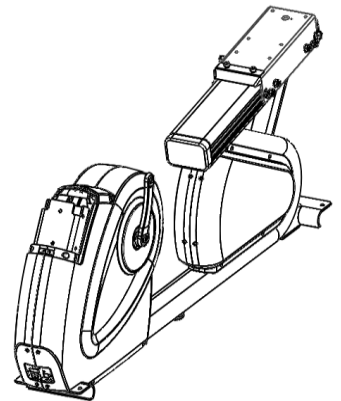

Body\*1

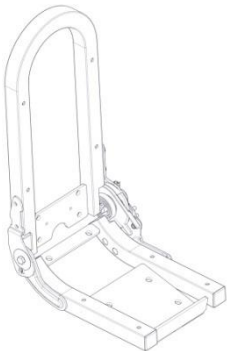

Adjustable Seat\*1

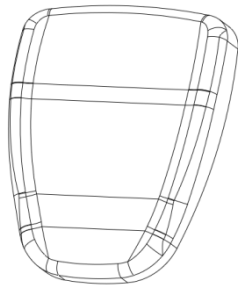

Seat Back Pad \*1

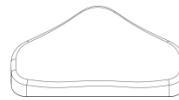

Seat Paddle\*1

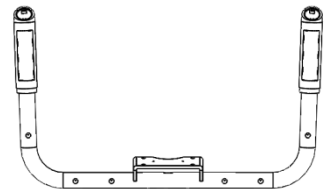

Lower Handle Assembly\*1

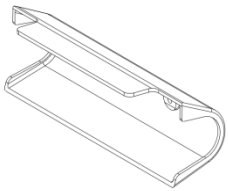

Lower Handle Trim  
Cover\*1

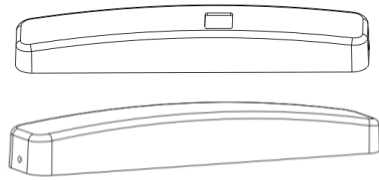

Left / Right Seat Slider Track Covers\*1

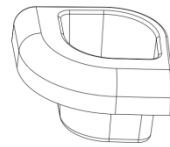

Bottle Holder\*2

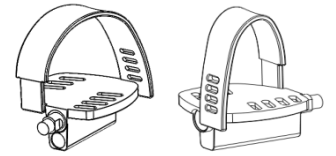

Left / Right Pedal\*1

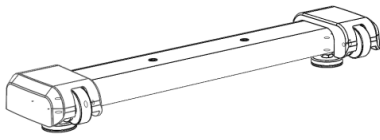

Front Stabilizer\*1

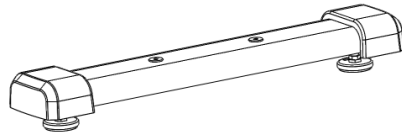

Rear Stabilizer\*1

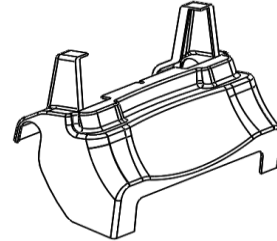

Lumbar Trim Cover\*1



Accessory Pack\*1

## 2.4 Accessory Pack

### Required for Step 4



Hex socket button head screw  
(M6x45mm\*8)



Spring washer  
(M6 \*8)

### Required for Step 5



Spring washer(M6 \*2)



Hex nut(M6\*2)

### Required for Step 7

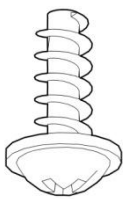

Philips screw  
(M4x12mm \*6)



Hex socket cap screw  
(M8x65mm\*2)

### Required for Step 12



Hex socket cap screw  
(M8x15mm\*1)



Curved washer  
(M8 \*2)



Spring washer  
(M8 \*3)

### Required for Step 13



Hex socket button head screw  
(M5x35mm\*4)



Philips screw  
(M3x8mm\*2)

## Others



L-shaped Hex  
Wrench with Screw  
Driver  
6-95mm\*1



L-shaped Hex  
Wrench with Screw  
Driver  
5-76mm\*1



L-shaped Hex  
Wrench  
4-61mm\*1



L-shaped Hex  
Wrench  
8-98mm\*1



L-shaped Hex  
Wrench  
3-55mm\*1



Wrench  
15mm\*1  
10mm\*1

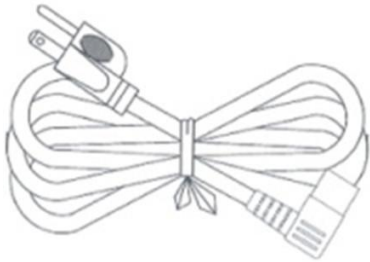

Power Cord \*1

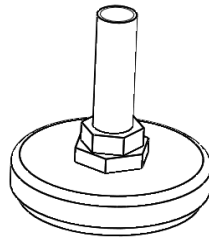

Leveling Foot\*1

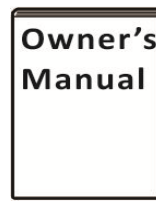

Owner's Manual \*1

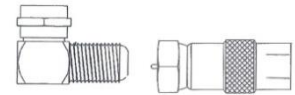

Coaxial Cable Adaptor (Applicable for  
EPlus console)

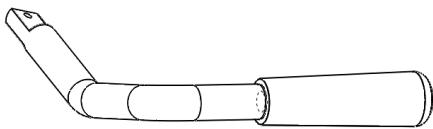

Right slider adjustment lever \*1

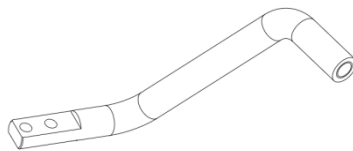

Left incline adjustment  
lever \*1

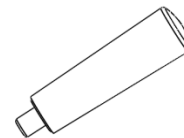

Lever handle \*1



Anti-slip rubber  
sticker \*1

## 2.5 Assembly Procedure

### Carton Removal

Prior to opening the shipping box, first you need to cut the fiberglass straps from around the wrapped carton and remove the upper carton cover upward. Then, take out all parts, accessory pack, and the body sequentially. Before beginning assembly, it is recommended to place a protective mat under the packaging and parts to prevent scratches. **Note: Due to the weight of the equipment, it is strongly advised to have a second person assist with the assembly.**

### Assembly

Step 1: As shown in the left picture, use a hex wrench to secure the front and rear stabilizers to the body using the pre-installed four hex socket cap screws (M8x20mm), four M8 spring washers, and four M8 flat washers. As in the right picture, install the leveling foot from the accessory pack under the body center. Loosen the fastening nuts of the leveling feet and adjust the height of each foot until all five are level. Once leveled, tighten the fastening nuts.

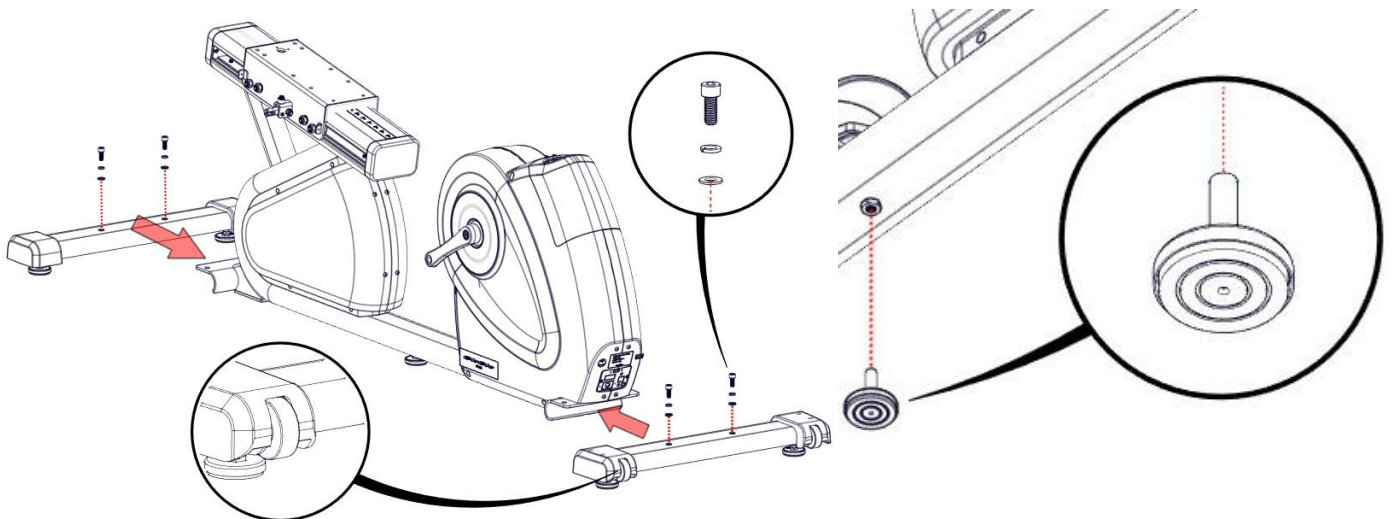

Step 2: Use a hex wrench to fasten the adjustable seat to the seat slider using the six pre-installed hex socket cap screws (M10x25mm) and six M10 spring washers.

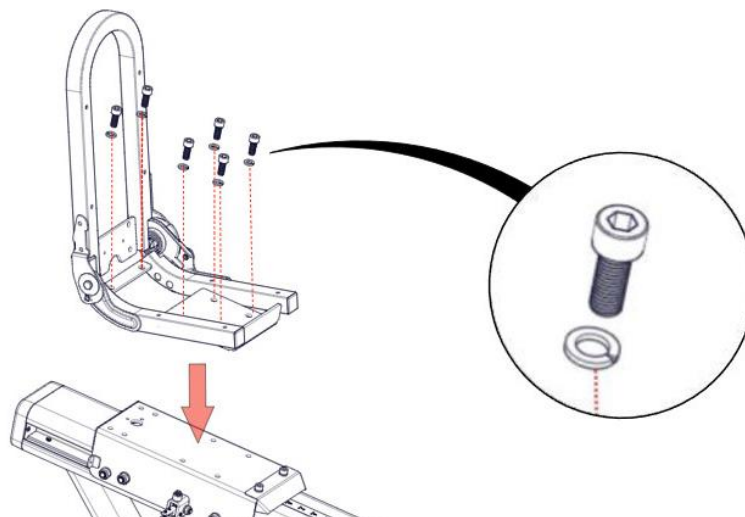

Step 3: Using a hex wrench, fasten the lower handle assembly to the adjustable seat with four pre-installed hex socket cap screws (M8x15mm) and four M8 spring washers.

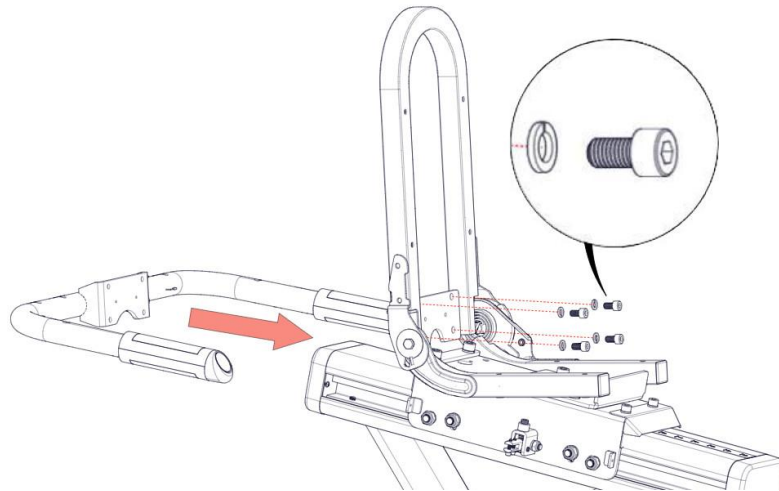

Step 4: Use a hex wrench to attach the seat paddle and seat back pad to the adjustable seat using eight hex socket cap screws (M6x45mm) and eight M6 spring washers from the accessory pack.

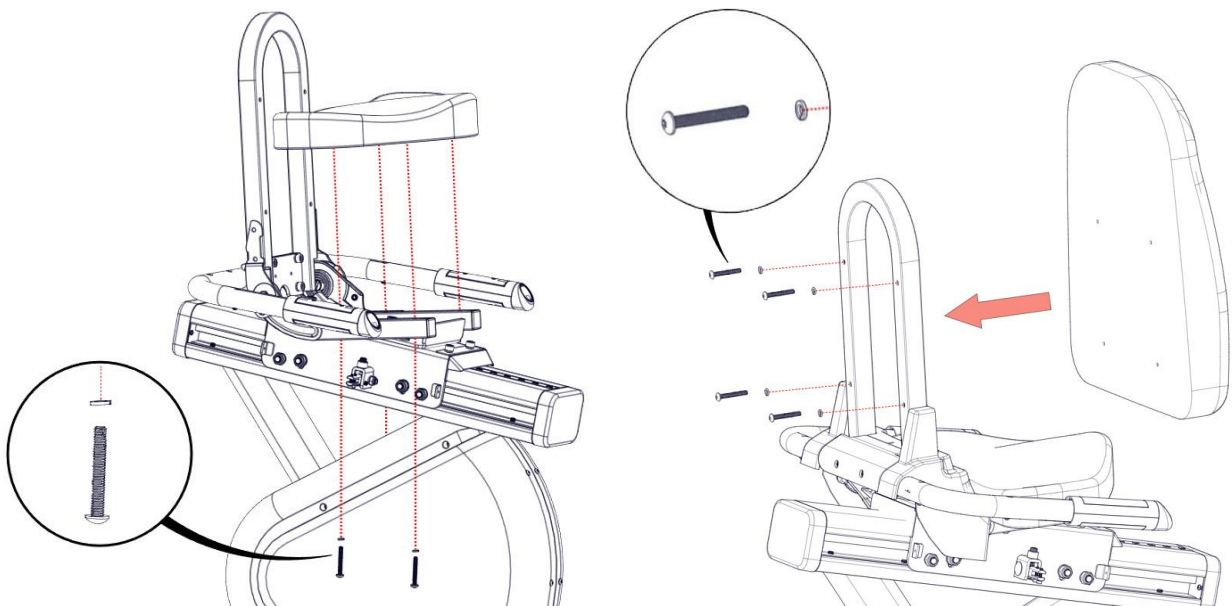

Step 5: Use a hex wrench to attach the left incline adjustment lever to the adjustable seat using two M6 hex nuts and two M6 spring washers from the accessory pack. Then, screw the lever handle into the lever shaft.

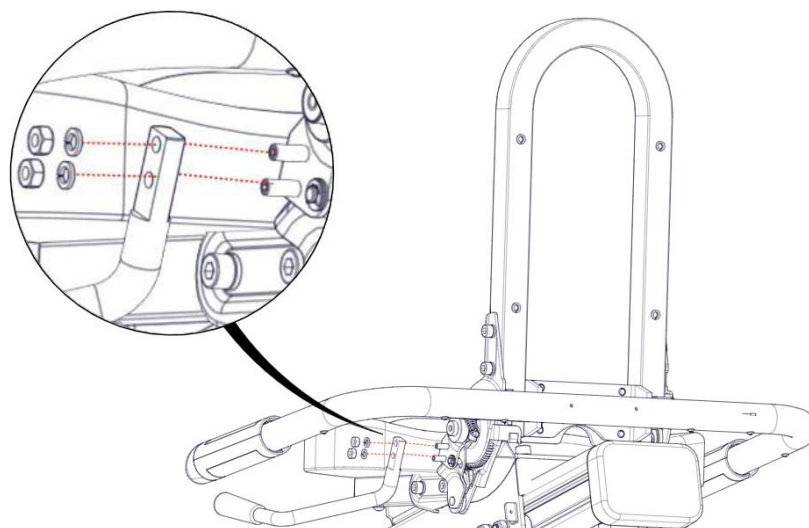

Step 6: Use a Phillips screwdriver to install the lower handle covers onto the adjustable seat using two pre-installed Phillips screws (M4x10mm).

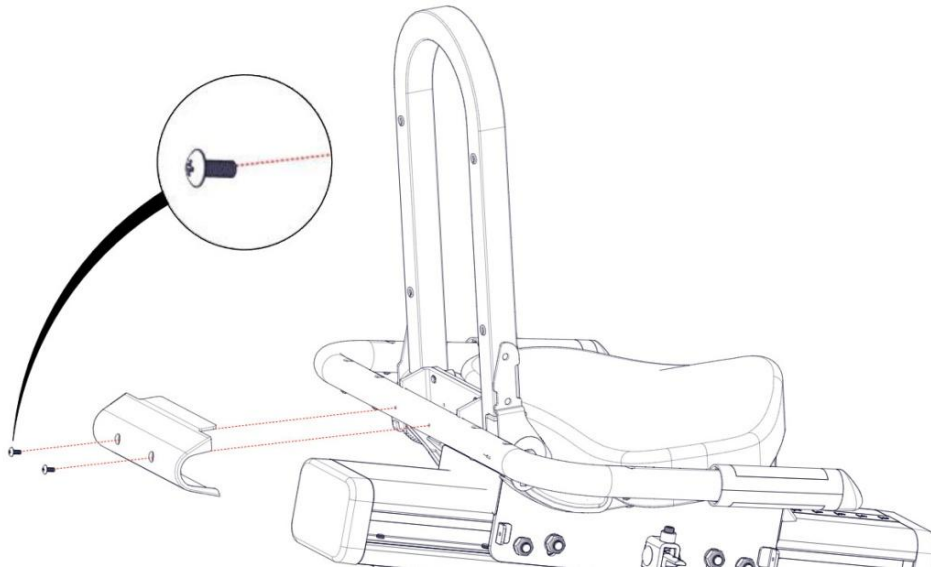

Step 7: Use a Phillips screwdriver to attach the lumbar cover and two water bottle holders to the adjustable seat using six Phillips screws (M4x12mm) from the accessory pack.

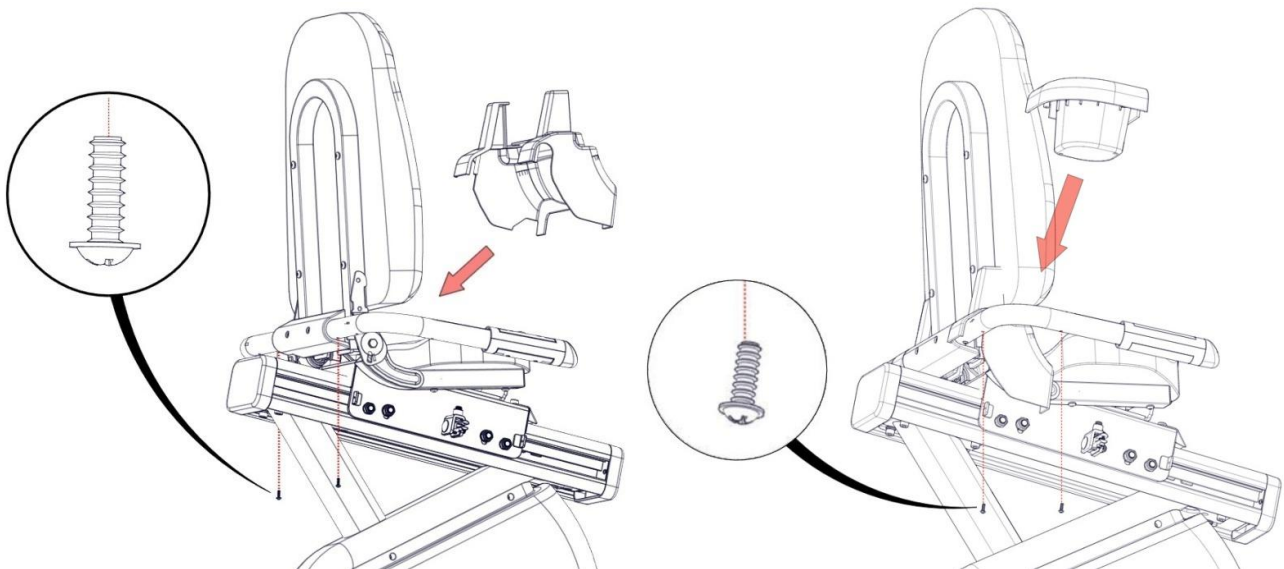

Step 8: As shown in the left and right pictures, use a Phillips screwdriver to install the slider track covers and right slider adjustment lever onto the seat slider using the pre-installed four Phillips screws (M4x10mm) and two Phillips screws (M4x18mm).

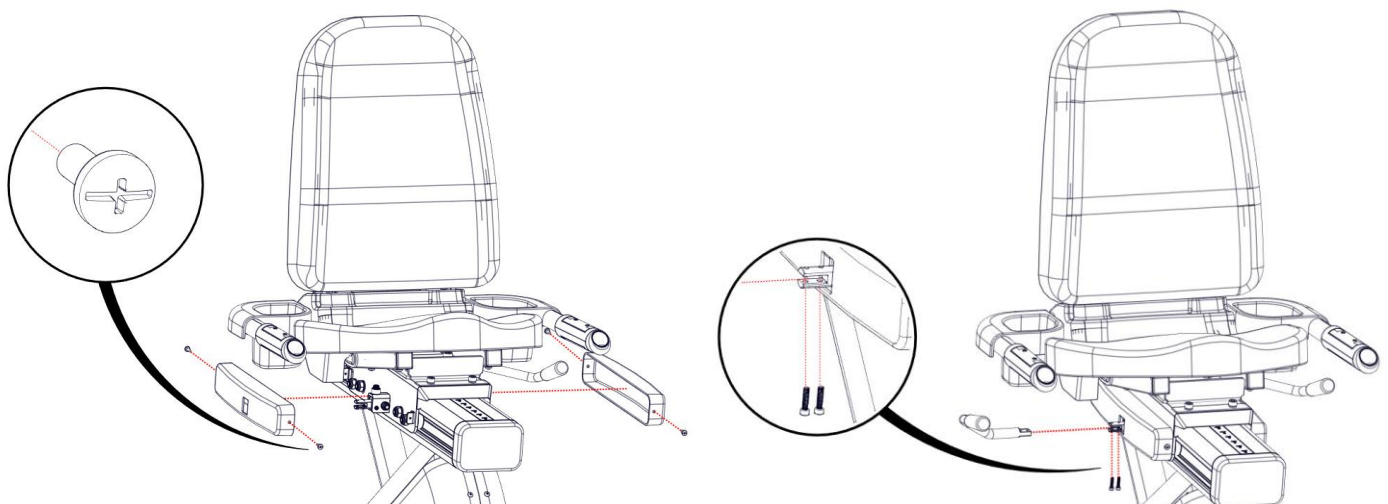

Step 9: Use a wrench to install the right and left pedals onto the crank arms.

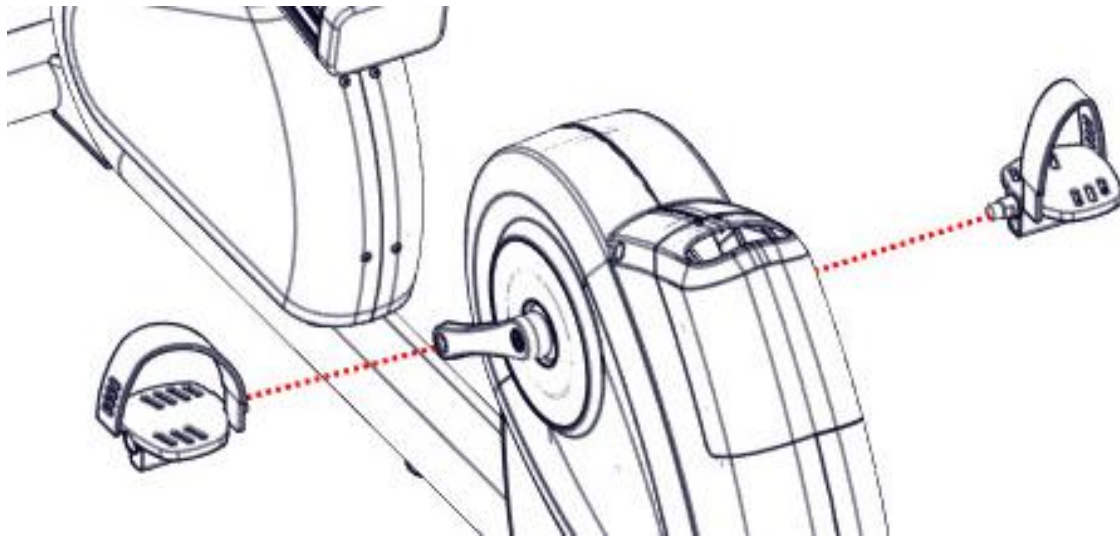

Step 10: Route the wires and install the mast onto the body

- Use a Phillips screwdriver to loosen the two pre-installed Phillips screws (M4x15mm) on the mast cover. Slide the cover onto the mast.
- As shown by the long arrow in the picture, use the guide wire inside the mast to pull the wires (as listed in Step 13) from the bottom opening of the mast up through the top opening.
- Use a hex wrench to attach the mast to the body using the pre-installed one hex socket cap screw (M8x20mm), one hex socket cap screw (M8x70mm), four hex socket button head cap screws (M8x20mm), two M8 spring washers, and six M8 flat washers.

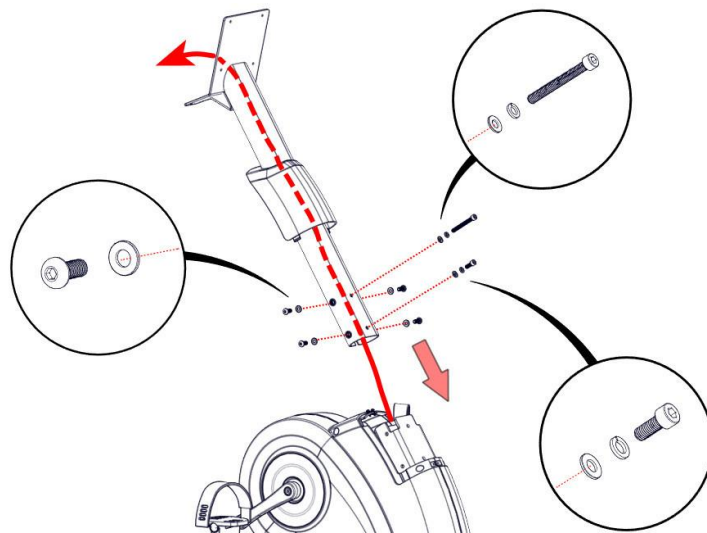

Step 11: Use a Phillips screwdriver to fasten the mast cover to the body using two pre-installed Phillips screws.

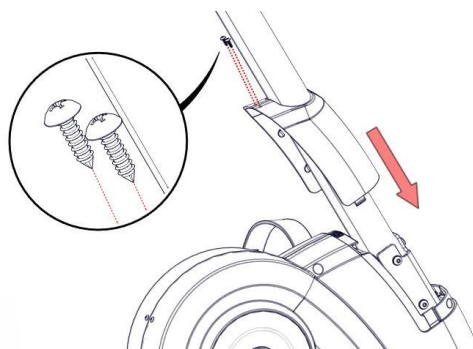



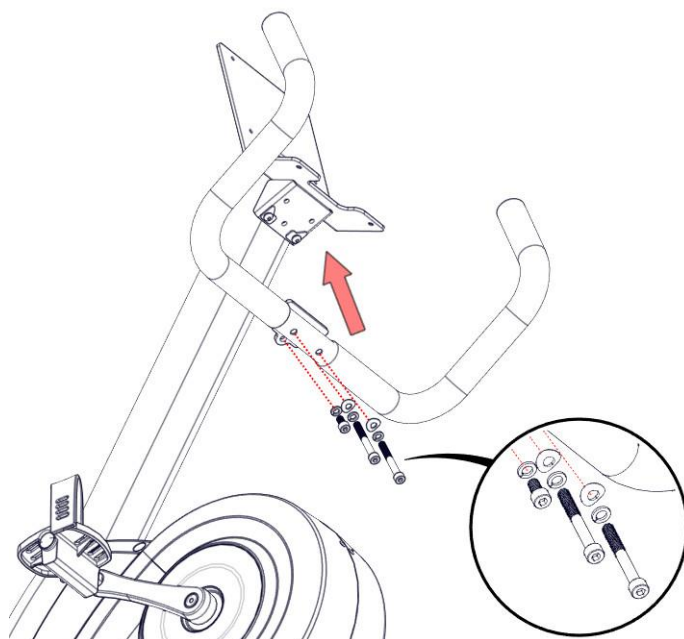

Step 12: Use a hex wrench to attach the upper handle assembly to the mast using two hex socket cap screws (M8x65mm), one hex socket cap screw (M8x15mm), two M8 curved washers, and three M8 spring washers from the accessory pack.

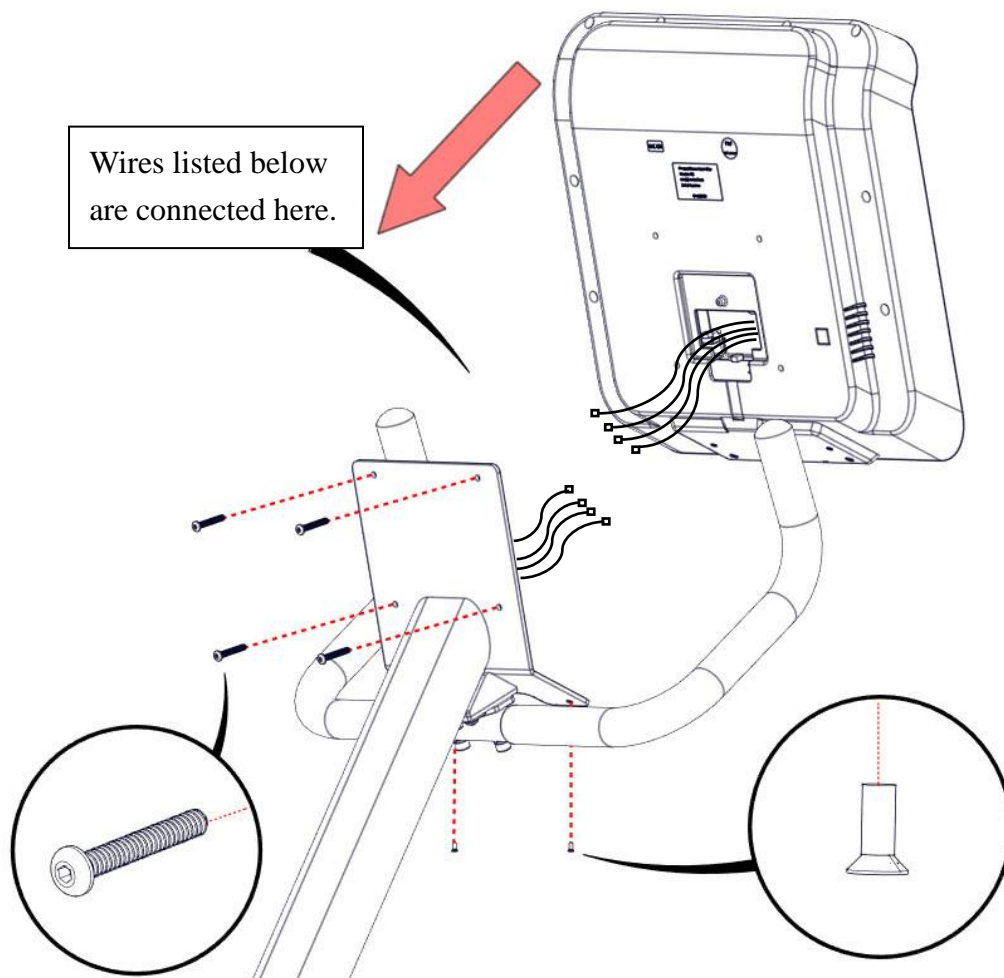

Step 13: Connect the wires from the mast to the corresponding wires from the console as listed in the table below. Then use a Phillips screwdriver and a hex wrench to secure the console to the mast using four hex socket button head cap screws (M5x35mm) and two Phillips screws (M3x8mm) from the accessory pack.

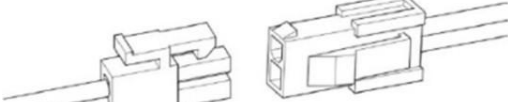

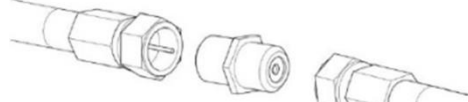
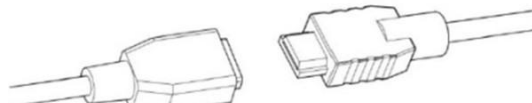
	<p>Console Wire</p>
	<p>LAN Wire (Only for EPlus / Sport model)</p>
	<p>Power Cable (Only for EPlus / Sport model)</p>
	<p>Wireless Charging Wire (Only for EPlus / Sport model)</p>
	<p>Resistance Control and Hand Pulse Wire (4 pin connector *2)</p>
	<p>Coaxial TV Cable (Only for EPlus model)</p>
	<p>HDMI Cable (Only for EPlus model)</p>

Step 14: Attach the anti-slip rubber stickers from the accessory pack to the designated areas shown in the picture.

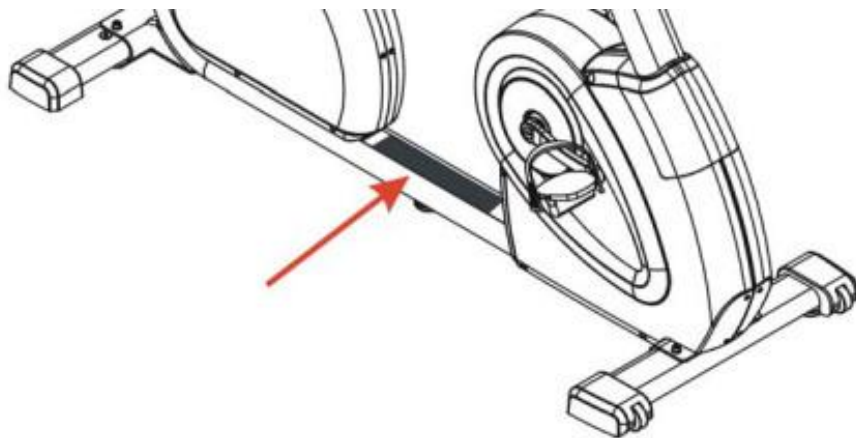

## 2.6 Engineering Mode Settings

Please refer to the owner's manual of the console for details on the [Engineering Mode Settings] section.

## 2.7 Operation

### Test Operation

Follow the instructions below to test the full resistance and ensure proper functionality:

- Step onto the pedals and begin pedaling while holding the handles for stability.
- Check if the console screen lights up normally.(Applicable to self-generation models)
- Test the full resistance range in sequence:
  - A. Press the "Resistance Increase (+)" button until the equipment reaches the maximum resistance level.
  - B. Press the "Resistance Decrease (-)" button until the equipment reaches the minimum resistance level.
- When the pedals come to a complete stop, hold the handles securely before stepping off the machine.

### Heart Rate Measurement

Place both palms directly on the heart rate sensor handles and maintain contact with the sensor area for an accurate heart rate measurement. After approximately 5 seconds, your heart rate reading will appear on the screen. Avoid gripping the sensor handles too tightly - gently rest your hands with moderate pressure. If you see an unusually high or unstable heart rate reading, allow the display to reset to zero before testing again. Do not operate the heart rate sensors while exercising; it is recommended to hold the sensor handles only when you need to check your heart rate.



### Chest Belt (Optional)

Position the chest belt just under your pectoral muscles or sports bra. **CAUTION:** To read an accurate and consistent reading, the chest belt should be fairly tight around the torso and just tighter than is comfortable.

### Consult Your Physician Immediately

- **WARNING:** Consult your physician before starting any exercise program, especially if you are over 35 years old or have existing health conditions.
- Read all instructions before using the equipment.
- The company is not responsible for any personal injury or property damage resulting from the use of this equipment.

### Exercise Recommendations

- **Frequency:** It is recommended to exercise 3 to 4 times per week to improve cardiovascular and muscular health.
- **Intensity:** Heart rate reflects exercise intensity and should be determined by a physician, reaching a level that strengthens the heart and improves the cardiovascular system.
- **Intervals:** Continuous exercise helps train the heart, lungs, and muscles. Beginners should maintain a steady pace for 2 to 3 minutes before checking their heart rate.

## Handling Abnormalities

If the equipment malfunctions, immediately turn off the power and unplug the device. Contact your dealer for assistance and do not attempt to disassemble the equipment yourself, as this may pose a safety risk.

# 3 Maintenance and Repair

## 3.1 Regular Maintenance

**WARNING: Always unplug the power cord before cleaning, lubricating, or performing any maintenance work.**

The safety of the equipment can be maintained only if it is examined regularly for damage or wear. If maintenance is required, keep the equipment out of use until defective parts are repaired or replaced. The following preventive maintenance tips will keep the machine operating at peak performance:

- Store in a cool, dry place.
- Keep the screen free of fingerprints and sweat residue buildup.
- Avoid pressing the control panel with long fingernails to prevent scratches; use your fingertip instead.
- Clean the equipment surface with a 100% cotton cloth slightly dampened with water or a mild liquid cleaner. Avoid using paper towels or any abrasive materials.
- Do not use cleaners containing ammonia or acidic ingredients.

### Preventive Maintenance Schedule (W for Wipe, V for Visual Inspection)

Item	Parts	Daily	Weekly	Monthly	Quarterly	Semi-Annually
1	Console screws					V
2	Body	W		V		
3	Pedals and cranks	W		V		
4	Power cable			V		
5	Console overlay	W		V		
6	Heart rate handle	W	V			
7	Resistance button	W	V			
8	Drive belts and groves				V	
9	Adjustable seat and seat slider				V	
10	Bottle holder	W				
11	All cosmetic plastics	W				

## 3.2 Warranty Claim

Please first visit the official website at <https://www.circlefitness.com/support/> to download the service manual as a dealer for troubleshooting. If the issue is not resolved, please go to <http://goo.gl/forms/OplmbWO9kXHJuDYc2> to submit warranty claims. Please provide information as mentioned below and upload your pictures/video clips. Automatic confirmation email will be sent out via [warranty.claim259@gmail.com](mailto:warranty.claim259@gmail.com) so please make sure this email address is not blocked by your server or email software.

- Vendor's code
- Your email address
- Your name
- Your phone number
- Model description: Please refer to the "Model" field on the equipment label and enter the appropriate model, such as M8, M8 EPlus, M8S, M8T, E8, E8T, E8S, E8 EPlus, B8, B8 EPlus, B8T, or B8S. Only one model can be submitted at a time.
- Serial Number: Please refer to the "Serial Number" field on the equipment label. The serial number consists of one letter followed by nine digits. The first letter represents the equipment type: **T** for treadmills, **E** for elliptical trainers, **R** for recumbent bikes, and **B** for upright bikes. The following nine digits include the manufacturing year and month as part of the serial sequence. You may fill in multiple serial numbers if you submit a warranty claim for the same model.

- Problem description:

Example 1: Incline window showed "Err". All functions of the treadmill are normal except the lift motor. Our engineer has made diagnostics according to the document "Engineering Manual - Trouble Shooting". Also there is a loud noise while pressing the "UP" button. So, he considers the lift motor to be faulty.

Example 2: Display problem: One LED segment is always off.

- Issue solved or not? Solved/ Not solved yet/ others
- Requested Part Name/Number
- Link to the Folder of Pictures/Video Clips: Photos of **warranty labels** are essential for warranty claims on electronics like console, lift motor, inverter, generators and etc.
- End Customer Site Description and Contact
- Reported Failure Date
- Preferred Shipping Method
- Comments: Please leave comments for this issue here if you have any





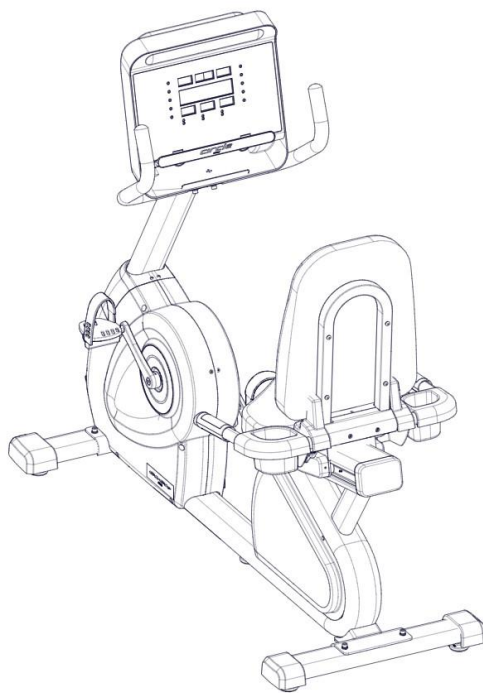

***circle***  
*FITNESS*

---

ALWAYS MOVING FORWARD



[www.circlefitness.com](http://www.circlefitness.com)