

circle

FITNESS

ALWAYS MOVING FORWARD

Owner's Manual



M6 Treadmill

Assembly

(The LED Console picture is an example)

Table of Content

1	SAFETY INFORMATION	3
1.1	Important Safety Notes	4
1.2	Equipment Label and Serial Number.....	5
1.3	Equipment Placement and Spacing.....	5
1.4	Transportation	6
1.5	Power Requirements	6
1.6	Proper Power Cord Connection and Placement.....	6
1.7	Facility Power Requirements	7
1.8	Receptacle Requirements	8
1.9	Actual vs. Maximum Current Rating.....	8
1.10	Television Connection Requirements (If Applicable).....	9
1.11	CSAFE Port (If Applicable).....	9
1.12	Internet Requirements (If Applicable)	10
1.13	Installation Checklist	11
2	Specification and Assembly.....	12
2.1	Specification	12
2.2	Machine Overview	13
2.3	Parts.....	13
2.4	Accessory Pack	14
2.5	Assembly Procedures.....	16
2.6	Engineering Mode.....	20
2.7	Tread Belt Adjustment	20
2.8	Operation.....	21
3	Maintenance and Repair	23
3.1	Regular Maintenance	23
3.2	Tread Belt and Deck Lubrication Maintenance	24
3.3	Warranty Claim	25

Dear Customer,

Thank you for selecting Circle Fitness. This product provides an impressive selection of features designed to make your workouts more effective and enjoyable.

For your benefit, read this manual carefully before using the product. If you need the latest version of the owner's manual, you can also visit the official website at <https://www.circlefitness.com/support/> and download it as a dealer.

If you still have any questions after reading the manual, please note the product model and serial number located on the front cover and contact us via email at service@circlefitness.com.



ALWAYS MOVING FORWARD

Address: No. 12, Industrial Park 6th Road, Taichung 407257, Taiwan

Telephone: +886-4-2359-1009

Fax: +886-4-3505-5801

Email: service@circlefitness.com

Website: <http://www.circlefitness.com/>

1 SAFETY INFORMATION

IMPORTANT: Please read all instructions and warnings before assembly and operation.

To assure the correct use of the product, basic safety measures should always be followed including the warnings and cautions listed in this owner's manual.

SAFETY SYMBOLS USED IN THIS MANUAL	
WARNING	Indicates a potentially hazardous situation which, if not avoided, could result in death or serious injury.
CAUTION	Indicates a potentially hazardous situation which, if not avoided, may result in minor / moderate injury to the user / patient or result in damage to the equipment or other property.
DANGER	Indicates a high probability that death, severe bodily injury or major property damage could result.



IMPORTANT: It is essential that this equipment is only used indoors in a climate-controlled room.

WARNING: Only one person at a time should use this equipment. If dizziness, nausea, chest pains, or any other abnormal symptoms are experienced while using this equipment then please stop the workout at once.

WARNING: Always use this equipment on a clear and level surface. Do NOT use outdoors or near water.

WARNING: Do NOT drop or insert any object into any openings.

WARNING: Do NOT wear loose clothing or jewelry. This equipment has moving parts. Do NOT put fingers or other objects into the moving parts.

WARNING: Before using this equipment to exercise, always do stretching exercises first, to properly warm up.

WARNING: It is recommended to replace defective components immediately and keep the equipment out of use until repairs have been made by an approved technician.

WARNING: Always keep children under age 14 and pets away from the equipment.

WARNING: Please consult your physician before starting a workout or a training program. It is best to have your doctor review your training and diet programs first so that they can recommend the best workout routine for you.

WARNING: Make sure all screws and nuts are securely tightened before using this equipment. Periodic maintenance is required on all exercise equipment to keep it in good condition.

WARNING: Keep your back straight while using this equipment; do not arch your back.

FCC Compliance (If Applicable)

The components of this equipment have been tested and found to comply with the limits for a Class B digital device, pursuant to part 15 of the FCC Rules. These limits are designed to provide reasonable protection against harmful interference in a residential installation. This equipment generates and can radiate radio frequency energy and, if not installed and used in accordance with the instructions, may cause harmful

interference to radio communications. However, there is no guarantee that interference will not occur in a particular installation. If this equipment does cause harmful interference to radio or television reception, which can be determined by turning the equipment off and on, the user is encouraged to try to correct the interference by one or more of the following measures:

- Reorient or relocate the receiving antenna.
- Increase the separation between the equipment and receiver.
- Connect the equipment into an outlet on a circuit different from that to which the receiver is connected.
- Consult the dealer or an experienced radio/TV technician for help.

1.1 Important Safety Notes

WARNING: Incorrect/excessive training can cause health injuries. Stop using the equipment when feeling uncomfortable.

WARNING: The heart rate sensor is not a medical device. Numerous factors, including the user's movement may affect the accuracy of the heart rate readings. The heart rate sensor is intended only as an exercise aid in determining heart rate trends in general.

WARNING: This equipment should not be used by any person weighing more than 400lbs (182 kg).

WARNING: Do not hold the handlebars or the console arms when mounting, dismounting, or using the equipment. Use the handlebars for stability only.

WARNING: Do not leave equipment unattended when plugged in. Turn all controls to OFF and unplug from outlet when not in use or before removing / replacing parts.

WARNING: Close supervision is necessary when the equipment is used by, on, or near children, invalids, or disabled persons.

WARNING: Use the equipment only for its intended use as described in this manual. Do not use attachments not recommended by the manufacturer.

WARNING: Never use the equipment if it has a damaged cord or plug, if it is not working properly, if it has been dropped or damaged, or has been dropped into water. Return the equipment to a service center for examination and repair.

WARNING: Do not carry the equipment by the supply cord or use the cord as a handle.

WARNING: Keep the cord away from heated surfaces.

WARNING: Never use the equipment with the air openings blocked. Keep the air openings free of lint, hair, and the like.

WARNING: Do not use where aerosol (spray) products are being used or where oxygen is being administered.

WARNING: Only connect the equipment to a properly grounded outlet. See Grounding Instructions.

WARNING: This equipment is intended for commercial use.

WARNING: Store the safety key in a secured location while not in use and keep away from children.

CAUTION: Ensure that the power cable is not pinched and that no one can trip over it.

CAUTION: Never touch the moving tread belt or rollers with your hands. Also ensure that there are no objects close to the rollers or tread belt which could be pulled into it thus causing injury or damaging the unit itself.

CAUTION: Repairs on the electrical components in the unit should be conducted by qualified technicians

only.

CAUTION: The equipment will generate more noise during operation under load compared to when it is running without a load.

DANGER: To reduce the risk of electric shock, always unplug this appliance from the electric outlet at once after using or before cleaning.



Waste Disposal: Products are recyclable. At the end of its useful life please dispose of this article correctly and safely. (Contact your local waste disposal facility)

1.2 Equipment Label and Serial Number

The image below shows the equipment label, which is located on the front cover of the machine. The serial number, highlighted by a red circle, consists of one letter followed by nine digits. The first letter represents the equipment type: **T** for treadmills, **E** for elliptical trainers, **R** for recumbent bikes, and **B** for upright bikes. The following nine digits include the manufacturing year and month as part of the serial sequence.



1.3 Equipment Placement and Spacing

Location

Before assembling the unit, verify the chosen site meets the following criteria:

- Area is well lit and well ventilated.
- Surface is structurally sound and properly leveled.
- Place in a location away from direct sunlight. The intense UV light can cause discoloration on the plastics.
- Locate your elliptical in an area with cool temperatures and low humidity.
- Do not install, use, or store the elliptical in an area of high humidity, such as in the vicinity of a steam room, sauna, indoor pool, garage, covered patio, near water or outdoors. Exposure to extensive water vapor, chlorine and/or bromine could adversely affect the electronics as well as other parts of the unit.
- Place the equipment on a level surface. Do NOT place it in any area that will block any vents or air openings.

Spacing

- Free area for access to the unit and emergency dismount. Minimum clearance is 20 inches (0.5 meters) on the sides of the unit and 79 inches (2 meters) behind the unit.
- Adjacent units may share the free area.
- The minimum spacing recommendations above are based on a combination of the ASTM F2115-19 (U.S.) voluntary standards and EN (European) regulations as of 2019 for access, passage around, and emergency dismount. ASTM standards are voluntary and may not reflect current industry standards. The actual area for access, passage around, and emergency dismount is the responsibility of the facility. The

facility should consider the total space requirements for training on each unit, voluntary and industry standards, and any local, state, and federal regulations. Standards and regulations are subject to change at any time.

1.4 Transportation

To move the equipment, carefully lift the rear end by pushing down on the 2 front transport wheels. Carefully steer the equipment to another location.

IMPORTANT: Be careful when moving this equipment, as it is heavy and awkward. If you do not feel comfortable moving the unit by yourself, please get help.

CAUTION: The transport wheels are designed for indoor use only and should not be used to move the unit over rough surfaces such as concrete or asphalt.

1.5 Power Requirements

All building electrical power and wiring shall comply with the currently adopted electrical codes in your area.

WARNING: Failure to follow these specifications can cause damage to your product and can void the warranty.

- All power outlets must be functional the day of delivery/assembly of the product. The client is responsible for any added installation charges associated with return visits.
- Electrical supply may fluctuate in your area. To ensure the stable performance of the product, we require the following wiring gauges be used based on the distance between the unit and the panel:
 - 100 ft. (30.5 meter) or less = 12AWG
 - 101 ft. – 125 ft. (30.8 - 38.1 meter) = 10AWG
 - 126 ft. – 150 ft. (38.4 - 45.7 meter) = 8AWG
 - An electrical power supply run over 150 ft. (45.7 meter) is not recommended
 - Circle Fitness recommends circuit breakers designed to manage inductive loads. An example is the QO-HM120 breaker.

Power Information

Line Voltage (V)	Line Frequency (Hz)	Breaker Rated Current (A)	Maximum Power Dissipation under Safety Compliance Testing Conditions (W)
110 / 220	50~60	20 (110V Model) 15 (220V Model)	1650

1.6 Proper Power Cord Connection and Placement

- Do not use extension cords, modify the power cord or the plug provided with the equipment.
- Do not use an adapter to connect the plug to an ungrounded two-prong outlet. If a properly grounded outlet is not available, have one installed by a qualified electrician.

- Keep the power cord away from heated surfaces.
- Do not run the power cord across an area where it may become a tripping hazard or have the potential to receive damage from objects rolling over the cord.



Attention: Obtain the assistance of a licensed electrician before installing, modifying, or servicing any part of the electrical power

1.7 Facility Power Requirements

Branch Circuit

- When designing a facility or installing new Circle Fitness equipment into an existing facility, it is necessary to have the correct electrical power provisions. Without a proper electrical supply, the equipment will not run in a safe and proper manner.
- Dedicated outlets must not share line, neutral, or ground conductors with other outlets. This means that a single breaker, one hot wire, one neutral wire, and one ground wire are connected from the panel to a single electrical load. All circuits for equipments **SHOULD NOT SHARE A NEUTRAL OR A GROUND**. Each neutral wire and each ground wire should be tied back to the panel.

Isolated Circuit

The term "Isolated" has been misused in the past to describe an individual branch circuit. An Isolated circuit describes an electrical power circuit that is isolated from the rest of the electrical power in the building through a separate transformer. Circle Fitness equipment does not require isolated circuits. This is usually used only for equipment that is extremely sensitive to electrical noise in the power lines.

GFCI Outlet

The elliptical should not be connected to a GFCI circuit as the equipment needs a steady circuit flow and power shortages could lead to damaging components of your equipment. The equipment can cause nuisance tripping of GFCI's, which can result in damaged part(s) on the equipment. For an uninterrupted experience, do not use with GFCI outlets. If no suitable outlet is available, contact an electrician.



NEC (National Electric Code)

The National Electrical Code (NEC), or NFPA 70, is a U.S. standard for the safe installation of electrical wiring and equipment. It is part of the National Fire Codes series published by the National Fire Protection Association (NFPA). "National Electrical Code" and "NEC" are registered trademarks of the NFPA. While the NEC is not itself a U.S. law, NEC use is commonly mandated by state or local law, as well as in many jurisdictions outside of the United States. The NEC codifies the requirements for safe electrical installations into a single, standardized source.

1.8 Receptacle Requirements

The receptacle, for general purpose use, should be both grounded and polarized. The following is an example of NEMA 5-20P for standard socket configurations:

- A slot for a center- line- rounded pin: There must be a slot for a center- line- rounded pin (GROUND) connected to a common grounding conductor.
- Blade-shaped slots of different sizes: The two blade-shaped slots (NEUTRAL and HOT/LINE) must be of different sizes, to prevent ungrounded (2-wire) devices which use “neutral” as their only grounding from being misconnected.

Wall Receptacle

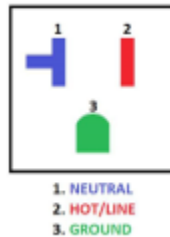

Power Cord Plug



The power cord supplied with the equipment comes with a region-specific plug and it must correspond to the receptacle that complies with local regulations. The figure below shows the international power receptacle guide.

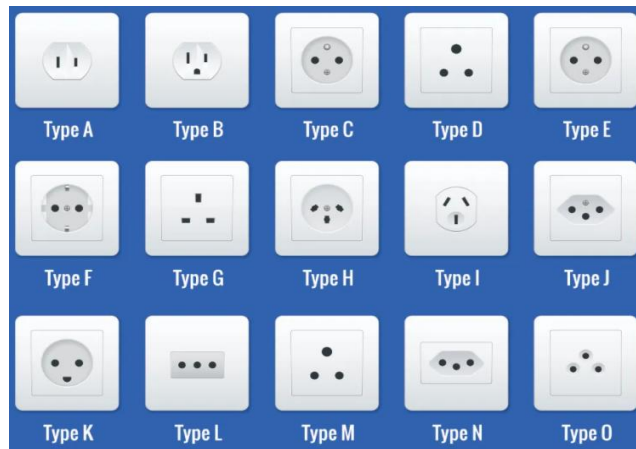

1.9 Actual vs. Maximum Current Rating

Generally speaking, a 15-amp fuse or circuit breaker is not actually intended to routinely carry 15 amps of power. In fact, a given circuit may only carry up to 80% of its maximum-rated capacity, with the remaining 20% intended as a safety margin. The following reference table shows the maximum rated capacity versus actual capacity.

Maximum Rated Circuit Capacity	Actual Circuit Capacity
10 A	8 A
15 A	12 A
20 A	16 A

1.10 Television Connection Requirements (If Applicable)

For live television on Circle Fitness equipment, coaxial cable must be run to the machine. All cabling internal to the fitness equipment will be supplied by Circle Fitness. All other cabling necessary to run from a TV or internet source to the Circle Fitness cardio product must be provided by the facility.

TV Cabling Requirements

The Circle Fitness touch screen equipped with a U.S. TV reception module supports the following three different types of TV signals used in the United States:

- NTSC (analog un-coded): old air broadcast, and un-coded cable TV
- ATSC (digital un-coded): used in current over-the-air broadcasts, and some un-coded cable TV
- QAM (digital cable): used in current un-coded and coded cable TV

In the US, some cable TV companies offer a basic package that does not require a set-top box – that signal acquired with any cable-ready TV. This type of service works best with Circle Fitness touch screen consoles as it uses either NTSC or ATSC/QAM Clear. The un-coded signal lets the facility simply connect the coaxial cable (RG6) to the connector on the Circle Fitness equipment and scan for channels.

Based on customer requirements, the Circle Fitness touch screen TV reception module can also support various digital TV broadcast standards used worldwide (ATSC, DVB-C, DVB-T, DVB-T2, ISDB-T, DTMB). However, the signal source must meet the following requirements:

- Signal must be delivered to the equipment unencrypted.
- Coaxial cable must be a quad-shielded RG6 cable with an F-Type compression fitting.
- Splitters or taps are acceptable for distributing signal, provided that the signal strength delivered to the equipment meets the required levels
- Confirm with your cable TV provider that the signal strength at each machine is adequate

1.11 CSAFE Port (If Applicable)

The CSAFE (Communication Specification for Fitness Equipment) port is a standard communication interface designed for fitness equipment, enabling data transmission, power supply, and external device connectivity. The CSAFE port on the Circle Fitness touch screen only provides power for small devices such as wireless audio receivers and transmitters, as shown in the picture in the right.



1.12 Internet Requirements (If Applicable)

As shown below, a download speed of at least 10Mbps is required to connect four Circle Fitness touch screens to the internet:

- Wireless Internet: A router/gateway and wireless access points (AP) must be installed. And it supports IEEE 802.11 ac/a/b/g/n Wi-Fi standards.
- Wired Internet: A router/gateway, CAT5e or CAT6 cables with RJ45 connectors are required.

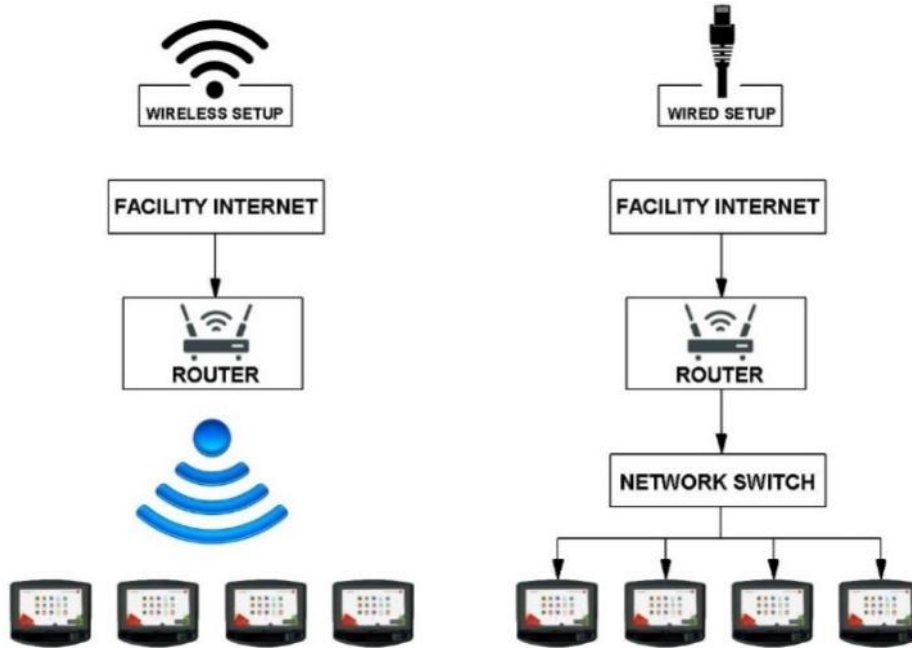

SAVE THESE INSTRUCTIONS FOR FUTURE REFERENCE

1.13 Installation Checklist

We created this basic installation guide to help you in the installation process of internet and/or TV to your Circle Fitness console. Here is a final installation checklist to help make the process run smoother.

POWER REQUIREMENTS	COMPLETED	N/A
Region-specific receptacles are ready		
Power supplied for Internet router/gateway		
CABLE TELEVISION REQUIREMENTS	COMPLETED	N/A
Confirm Television solution choice for equipment		
Coaxial cable runs to each machine		
Cat5e or Cat6 cable run to each machine (IPTV)		
INTERNET	COMPLETED	N/A
Sufficient bandwidth confirmed for the equipment (at least 10Mbps for four consoles)		
Wireless Network connected		
CHECKLIST ACKNOWLEDGEMENT		

Circle Fitness Representative: _____ Date: _____

Customer Representative: _____ Date: _____

2 Specification and Assembly

2.1 Specification

Technical Specifications		
Incline Range	0~16%	
Speed Range (kmh/mph)	0.8~20 / 0.5~12.5	
Maximum User Weight (kg/lb)	182 / 400	
Electrical Specifications		
Power Requirement	110V±10% / 220V±10% (50/60Hz)	
Motor Power (HP)	M6	M6DC
(Duty/Continuous)	3.5 / 2	4.25 / 3
Dimensions & Weight		
Packaged Weight (lbs/kg)	160 / 352	
Equipment Dimensions(LxWxH)(in/mm)	2150x985x1430 / 85x39x56	
Packaging Dimensions(LxWxH)(in/mm)	Mainframe 2276x972x415 / 90x38x16 Console Base 1051*889*409 / 41x35x16	
Console Specifications		
Console Type	LED (Applicable to M6/M6DC)	TOUCH (Applicable to M6)
Screen Type	2.8" TFT+LED Display	10.1" TFT
Programs	Training Courses (6 modes): Manual /Incline /Fat Burn /Cardio /Strength /Interval	
	Target Training (3 modes): Time /Distance /Calories	
	HRC(4 modes): Fat Burn /Aerobic /Performance /Custom	
	HIIT (2 modes): Preset (18 levels) /Custom	HIIT (4 modes): Normal / Hard / Advanced / Custom
	Physical Tests (7 modes): Gerkin Protocol / Cooper Test / USMC PFT / Army PFT / Navy PFT / USAF PFT / Federal Law	
USB Port	Yes (charging)	Yes (charging)
Hand Pulse Heart Rate	Yes	
Wireless Heart Rate	Yes	
Emergency Stop / Safety Key	Yes	
Bottle Holder	Yes	
CSAFE Port	Option	
Fan	Yes	
Wireless Charging	Option	

2.2 Machine Overview

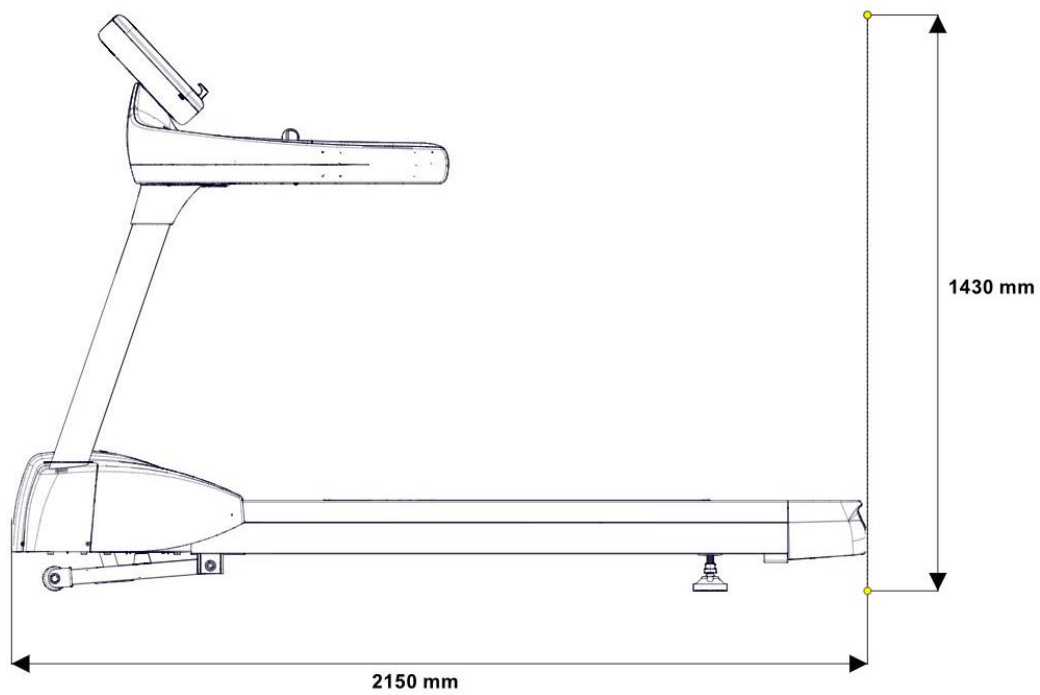
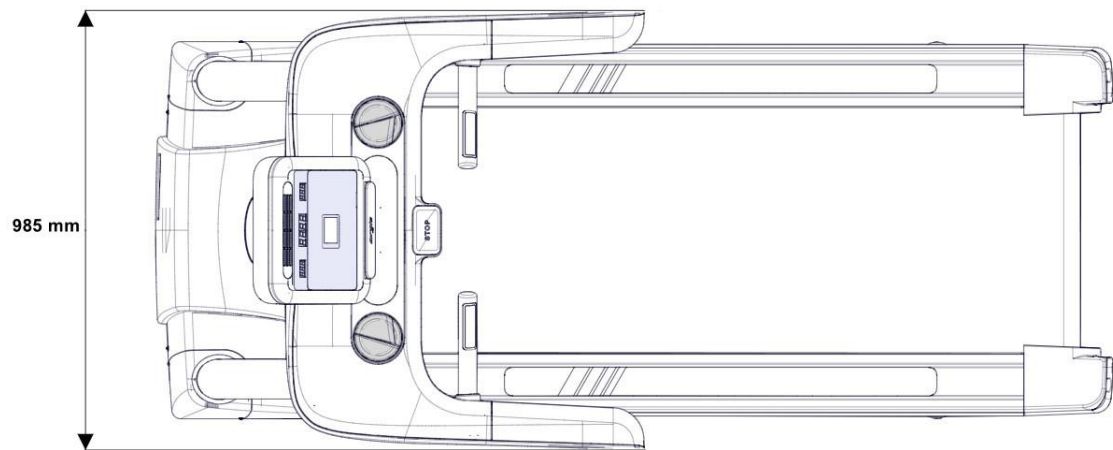

2.3 Parts

Mainframe Packaging

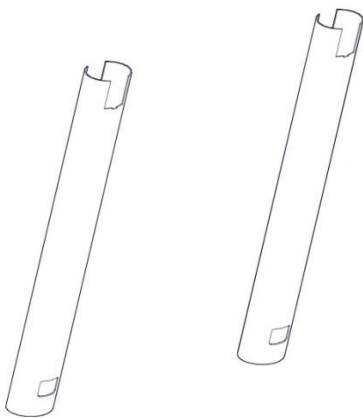

Masts

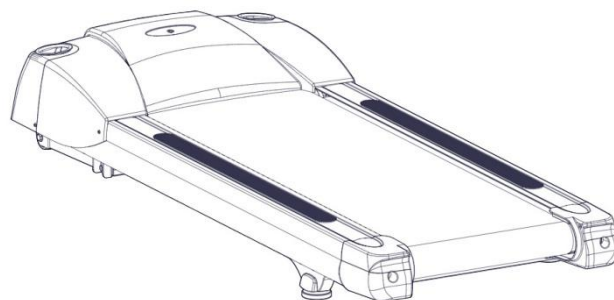

Mainframe



Accessory Pack

Console Base Packaging



Console Assembly

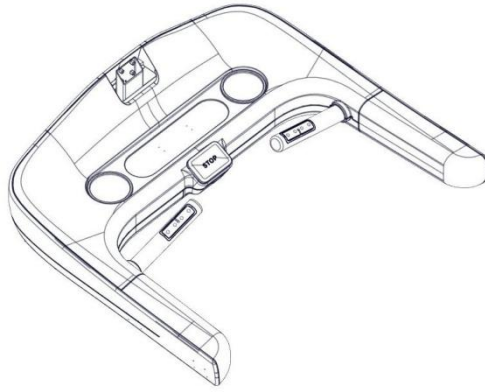

Console Base



Bottle Holder

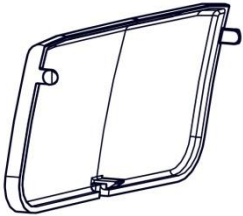

Console Rear Trim Cover

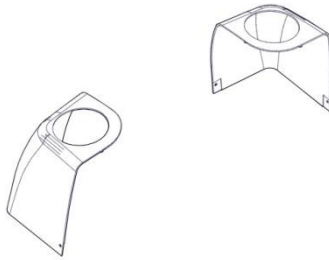

Lower Mast Trim cover

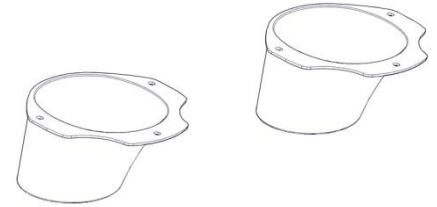

Upper Mast Trim Cover

2.4 Accessory Pack

Required for Step 2



Hex Socket Cap Screw(M8x20mm*6)



Hex Socket Cap Screw(M8x100mm*4)



Flat Washer(M8*14)



Spring Washer(M8*14)



Hex Nut(M8*4)

Required for Step 4



Hex Socket Cap Screw (M8x20mm *8)



Flat Washer (M8 *8)



Spring Washer (M8 *8)

Required for Step 5

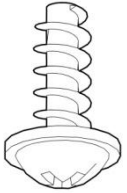

Philips Screw
(M5x15mm *4)

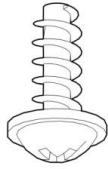

Philips Screw
(M4x15mm *6)

Required for Step 6



Hex Socket Cap Screw
(M6x15mm*4)



Flat Washer (M6*4)

Others



L-shaped Hex Wrench with Philips Screw
Driver 6-95mm*1



L-shaped Hex Wrench with Philips
Screw Driver 5-76mm*1



T-shaped Hex Wrench 6-124mm*1

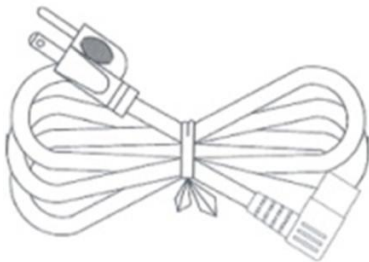

Power Cord *1



Lubrication Oil*1

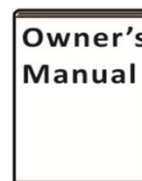

Owner's Manual *1

2.5 Assembly Procedures

Remove the packaging carton. Before beginning assembly, it is recommended to place a protective mat under the packaging and parts to prevent scratches. **Note: Due to the weight of the equipment, it is strongly advised to have a second person assist with the assembly.**

Step 1: Remove the Motor Cover.

Using a Phillips screwdriver, loosen and remove the two motor cover screws (M5 x 12mm) from the front and two motor cover screws (M5 x 15mm) from the side. Set the motor cover aside in a safe location.

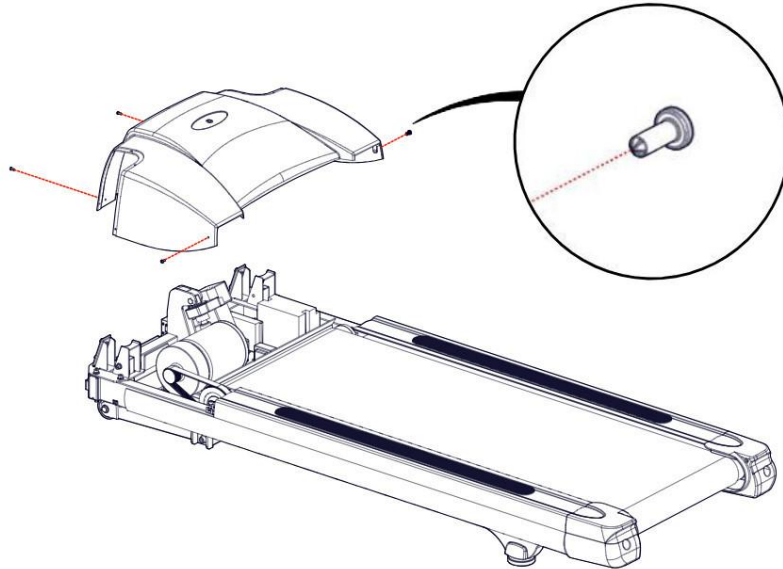

Step 2: Attach the left and right masts to the mainframe

Using a hex wrench, secure the left / right masts to the mainframe with those included in the accessory pack:

- 6 hex socket cap screws (M8 x 20mm) with 6 M8 spring washers and 6 flat washers.
- 4 hex socket cap screws (M8 x 100mm) with 4 M8 nuts, 8 M8 spring washers, and 8 flat washers.

Note: Do not fully tighten the screws at this stage. Leaving them slightly loose will make it easier to align the console base with the masts later.

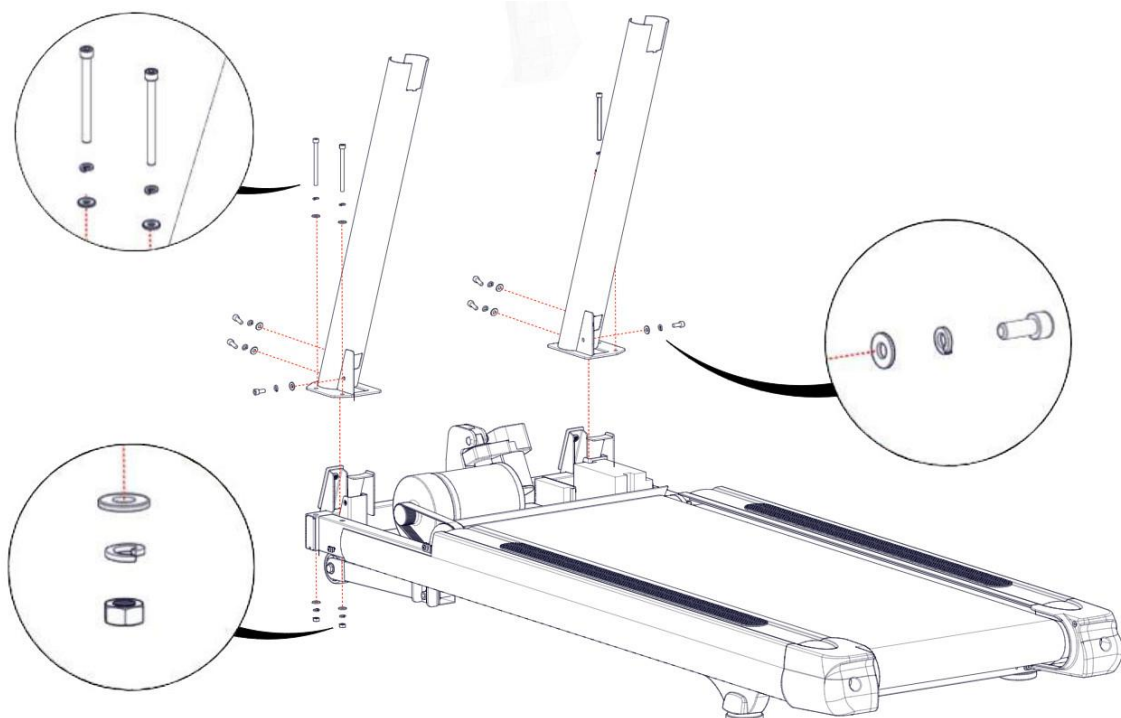

Step 3: Route the wiring into and out of the mast.

- Using the guide wire located inside the right mast, pull the cables listed in the table from Step 4 through the square opening at the bottom of the right mast into the mast, and then out through the top opening.

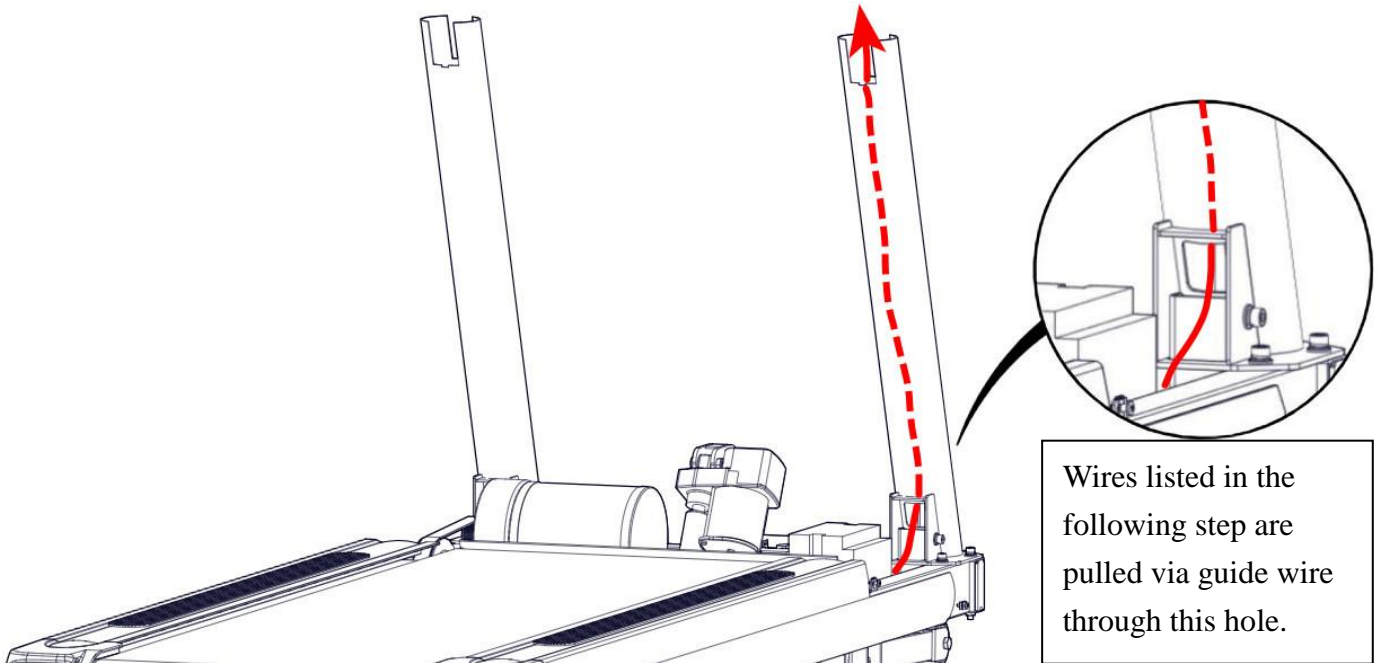



Wires listed in the following step are pulled via guide wire through this hole.

Step 4: Attach the console base to masts.

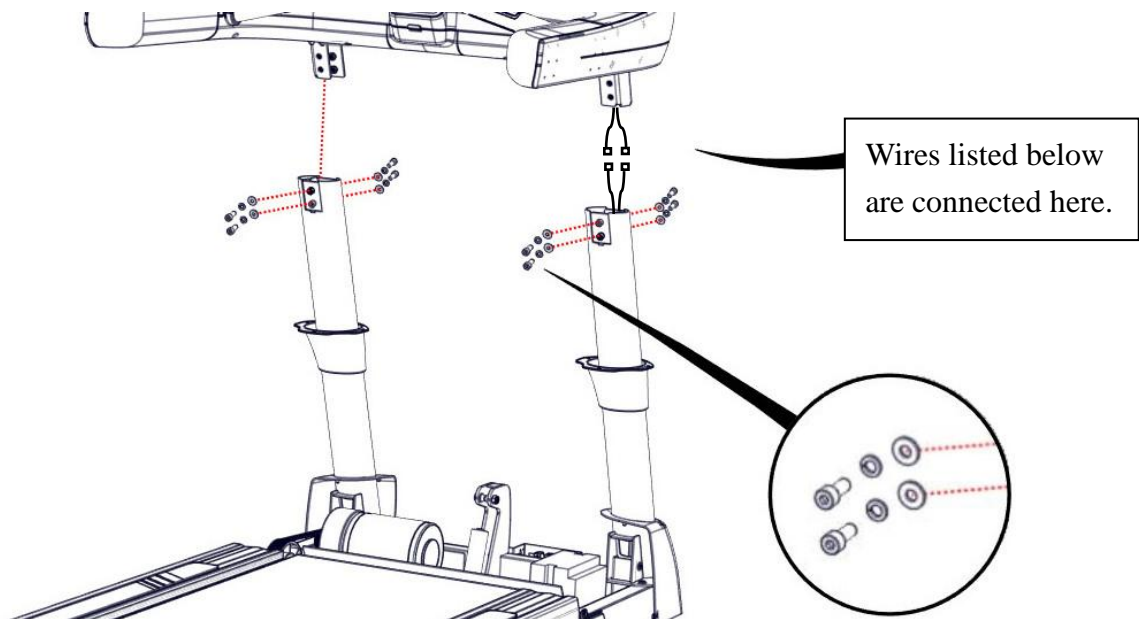
- Slide the upper and lower mast trim covers onto the masts
- Refer to the wiring chart below to match and connect the wires coming from the mast to the corresponding wires extending from the bottom of the console base. Once connected, carefully place the console base onto the masts.
- Using a hex wrench, secure the console base to the left and right masts with 8 hex socket cap screws (M8 x 20mm), 8 M8 spring washers, and 8 M8 flat washers from the accessory pack.
- Finally, use a hex wrench to fully tighten the 10 screws securing the left and right masts to the mainframe.



Wires listed below are connected here.

	Console Wire
	Wireless Charging Cable(Optional)

Note: Do not pinch or damage the wires during this process.



YES

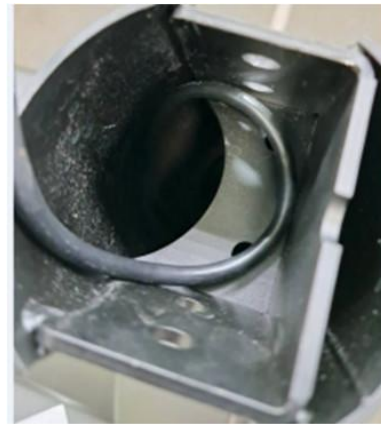

NO

Step 5: Install plastic covers such as trim covers.

- Using a Phillips screwdriver and screws from the accessory pack, fasten the upper mast trim covers to the underside of the console base with 6 Phillips screws (M4 x 15mm). Then fasten the lower mast trim covers to the mainframe with 4 Phillips screws (M5 x 15mm).
- Attach the water bottle holder to the console base.
- Using a Phillips screwdriver, reinstall the motor cover with 2 screws (M5 x 12mm) for the front side and 2 screws (M5 x 15mm) for the sides.

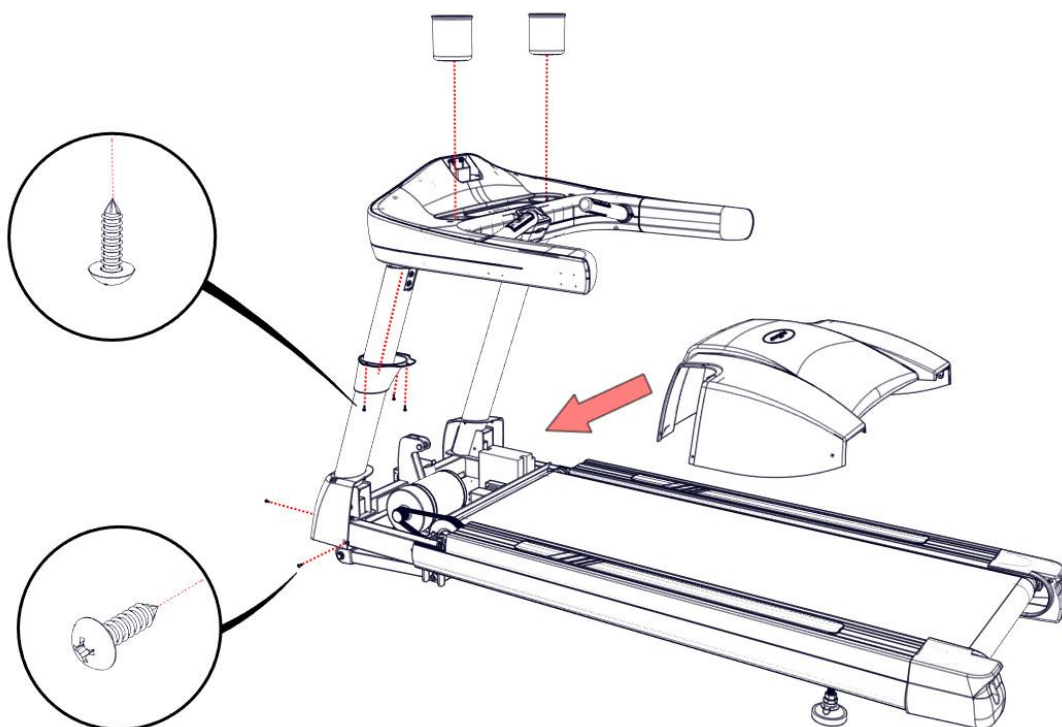

Step 6: Install the console assembly onto the console base.

As shown in the following table, connect the wires coming from the console assembly to the wires extending from the top of the console base. Then, use 4 hex socket cap screws (M6 x 15mm) from the accessory pack, along with 4 M6 flat washers, to secure the console assembly to the console base. **Caution: Be careful not to pinch or damage the wiring during installation.**

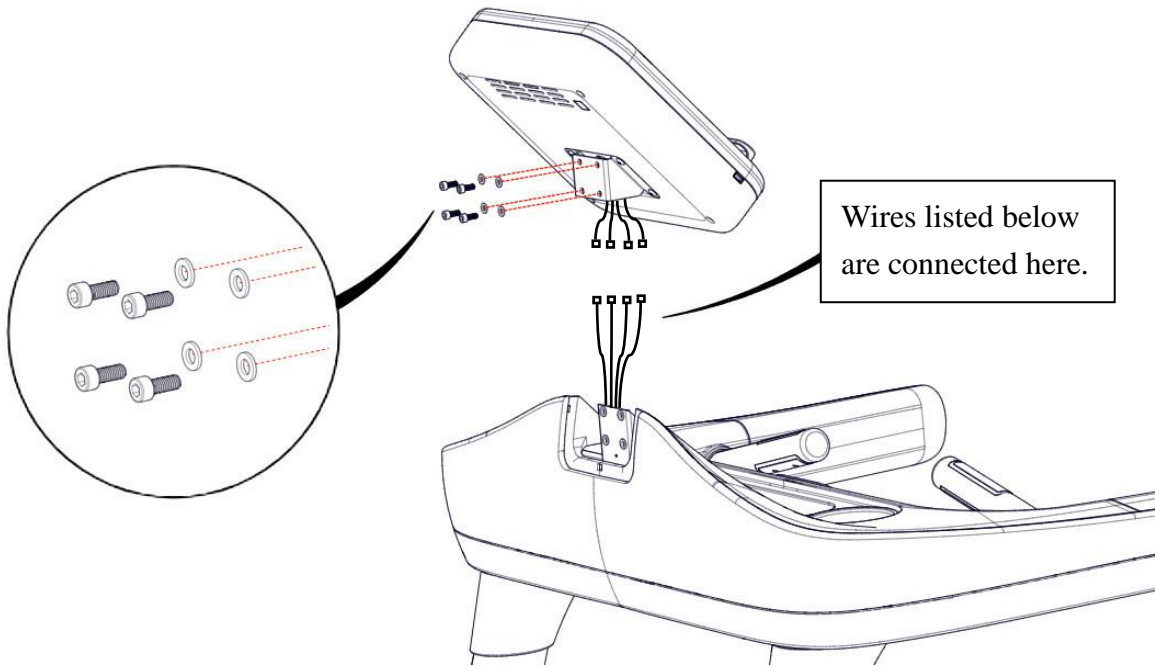

	Console Wire
	Safety Key Wire
	Hand Pulse Wire

Step 7: As shown in the image below, install the console rear trim cover.

Note: As indicated by arrow 1 in the image, first align and insert the pivot pin into the groove. Then, as shown by arrow 2, snap the latch into place.

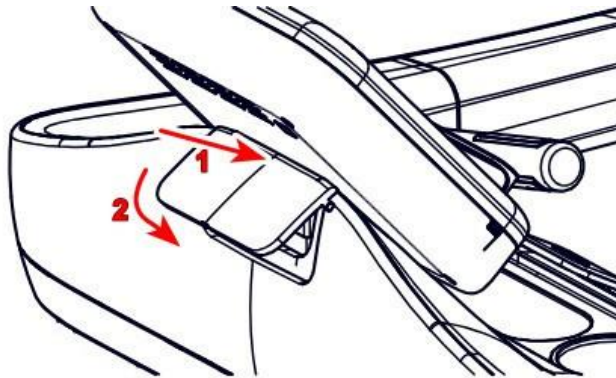

Step 8: Adjust the leveling feet.

First, remove the protective covers on the leveling feet. Loosen the fastening nuts of the leveling feet and adjust the height of each foot until all four are level. Once leveled, tighten the fastening nuts.

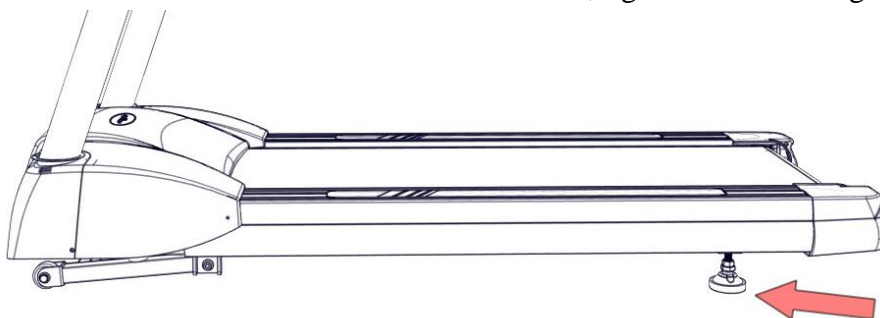

2.6 Engineering Mode

Please refer to the owner's manual of the console for details regarding Engineering Mode.

2.7 Tread Belt Adjustment

During the first few weeks of treadmill use, the tread belt may require adjustments. All tread belts are properly aligned and tensioned at the factory, but they can stretch or shift during initial use. This stretching is normal.

Tread Belt Running Area

The tread belt should remain centered within the area indicated by the arrows on the right and left roller covers. If the belt moves outside this range, it may cause premature wear or damage.

Centering the Tread Belt

When the user is running, uneven force from each foot can cause the belt to shift slightly to one side. This is normal and, in most cases, the belt will return to center when not in use. However, if the belt continues to drift, manual adjustment may be necessary as procedure below:

- Start the treadmill with no one standing on the belt. Increase speed to 4 mph (6 km/h).
- Observe whether the belt is drifting to the left or right:

A. If the belt is drifting to the left: Use a hex wrench to turn the left adjustment screw clockwise 1/4 turn and the right adjustment screw counterclockwise 1/4 turn.

B. If the belt is drifting to the right: Use a hex wrench to turn the right adjustment screw clockwise 1/4 turn and the left adjustment screw counterclockwise 1/4 turn.

C. If the belt is still not centered: Repeat the above steps until the belt is centered.

Once the belt is centered, increase the treadmill speed to 10 mph (16 km/h) and check for smooth operation. Repeat the steps above if necessary. If the belt remains off-center even after several adjustments, increasing the belt tension may help resolve the issue.

Adjusting Tread Belt Tension

If the belt slips while running or feels like it hesitates underfoot, the tension may need to be increased. Before making adjustments, ensure that silicone lubricant has been applied to the deck.

- To increase tread belt tension:
 - A. Using a 6mm hex wrench, turn the left tension adjustment screw clockwise 1/4 turn to tighten the rear roller and increase belt tension.
 - B. Repeat step A on the right tension adjustment screw. Be sure to turn both screws the same amount to keep the rear roller aligned with the main frame.
 - C. Continue repeating steps A and B until the belt no longer slips.
 - D. Mind that the tread belt should not be over tightened. Excessive tension can place undue stress on the front and rear roller bearings, leading to damage and increased noise.

- To decrease belt tension, turn both the left and right tension adjustment screws counterclockwise by **the same number of turns**.

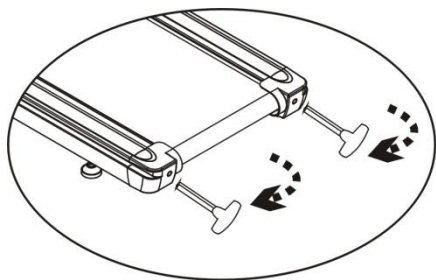

Turn clockwise to increase belt tension

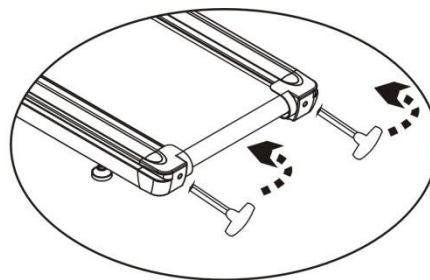

Turn counterclockwise to decrease belt tension

2.8 Operation

Heart Rate Measurement

Before or after your workout, stand on the side rails of the treadmill and gently hold the heart rate sensors with both hands. Do not grip the sensors tightly—simply rest your hands on them with light, steady pressure. After about 5 seconds, your heart rate will appear on the display. If the reading is unusually high or unstable, allow the reading to reset to zero before trying again. **Avoid using the heart rate sensors while exercising. It is recommended to hold the sensors only when you need to check your heart rate.**



Chest Belt (Optional)

Position the chest belt just under your pectoral muscles or sports bra. **CAUTION:** To read an accurate and consistent reading, the chest belt should be fairly tight around the torso and just tighter than is comfortable.

Emergency Stop Button

In case of an emergency where you need to quickly exit the equipment, hold onto the handrails and place your feet on the side rails, off the moving tread belt. Then, press the emergency stop button. The treadmill will come to an immediate stop.

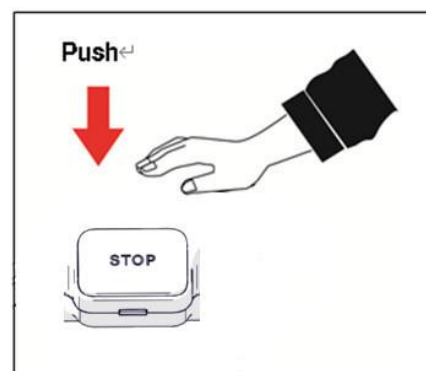

Safety Key

The safety key is designed to immediately stop the treadmill in case the user falls due to excessive speed or fatigue. Whether you're a beginner or an experienced user, always attach the safety key clip to your waistband before starting your workout.

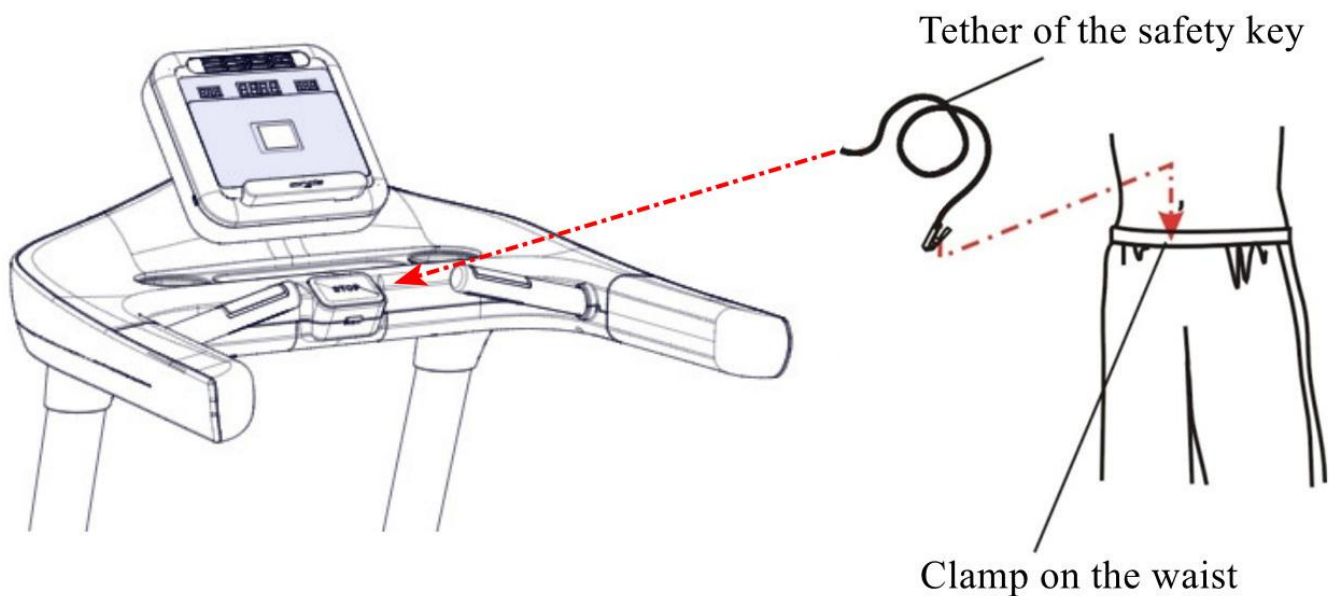

When to Use the Emergency Stop Button and Safety Key

Stopping the treadmill at high speeds using the emergency stop button or safety key may cause discomfort or pose a safety risk. Therefore, **these features should only be used in emergency situations**. During regular workouts, always press 「STOP」 button to bring the treadmill to a safe and comfortable stop.

Getting On and Off the Treadmill

- Use caution when getting on or off the treadmill, and use the handrails for support.
- When preparing to start, stand with your feet on the side rails. Only step onto the tread belt once it has reached a steady speed.
- Always ensure the tread belt speed is below 2 km/h (1.2 mph) before stepping on.
- During your workout, face forward at all times. Do not attempt to turn around while the treadmill is running.
- To end your workout, press 「STOP」 button and wait for the belt to come to a complete stop before stepping off.
- If you feel unwell or the speed becomes too fast, hold the handrails and lift your feet off the belt, placing them on the side rails to recover. It is recommended to begin your workout at a low speed for maximum safety and comfort.

Consult Your Physician Immediately

- **WARNING:** Consult your physician before starting any exercise program, especially if you are over 35 years old or have existing health conditions.
- Read all instructions before using the equipment.
- The company is not responsible for any personal injury or property damage resulting from the use of this equipment.

Exercise Recommendations

- Frequency: It is recommended to exercise 3 to 4 times per week to improve cardiovascular and muscular health.
- Intensity: Heart rate reflects exercise intensity and should be determined by a physician, reaching a level that strengthens the heart and improves the cardiovascular system.
- Intervals: Continuous exercise helps train the heart, lungs, and muscles. Beginners should maintain a steady pace for 2 to 3 minutes before checking their heart rate.

Proper Body Posture

- Warning: Do not walk or run backward on the treadmill.
- Avoid leaning too far forward or backward. Maintain proper posture by keeping your head up, shoulders aligned with your hips, arms relaxed with elbows at a 90° angle, and your eyes looking straight ahead.
- Your stride should be steady and rhythmic, with your legs and feet aligned parallel to the center of the tread belt.

Handling Abnormalities

If the equipment malfunctions, immediately turn off the power and unplug the device. Contact your dealer for assistance and do not attempt to disassemble the equipment yourself, as this may pose a safety risk.

3 Maintenance and Repair

3.1 Regular Maintenance

WARNING: Always unplug the power cord before cleaning, lubricating, or performing any maintenance work.

The safety of the equipment can be maintained only if it is examined regularly for damage or wear. If maintenance is required, keep the equipment out of use until defective parts are repaired or replaced. The following preventive maintenance tips will keep the machine operating at peak performance:

- Store in a cool, dry place.
- Keep the screen free of fingerprints and sweat residue buildup.
- Avoid pressing the control panel with long fingernails to prevent scratches; use your fingertip instead.
- Clean the equipment surface with a 100% cotton cloth slightly dampened with water or a mild liquid cleaner. Avoid using paper towels or any abrasive materials.
- Do not use cleaners containing ammonia or acidic ingredients.
- Clean off any wax buildup from the deck and tread belt area.

Preventive Maintenance Schedule (W for Wipe, V for Visual Inspection)

Item	Parts	Daily	Weekly	Monthly	Quarterly	Semi-Annually
1	Console screws					V
2	Main Frame	W				V
3	Running surface area		W			V
4	Power cord			V		
5	Keypad membrane / Console panel	W		V		
6	Handrails	W				V
7	Handrail screws				V	
8	Front roller and grooves				W	V
9	Rear roller					V
10	Safety key	W				
11	Drive belt				W	V
12	Tread belt tension					V
13	Motor control					W
14	Motor pulley and grooves					V
15	External plastic parts	W				

3.2 Tread Belt and Deck Lubrication Maintenance

Regular lubrication is essential for maintaining optimal performance and extending the lifespan of your treadmill. This maintenance step helps prevent premature wear of the tread belt, running deck, and motor drive system. While it can be difficult to determine the exact timing for lubrication, follow the schedule below as a general guideline:

Usage Level	Weekly Usage Hours	Lubrication Frequency
Light	Less than 3 hours	Every 4 months
Moderate	3–5 hours	Every 2 months
Heavy	More than 5 hours	Once a month

Note: To purchase treadmill-grade silicone lubricant, please contact your distributor.

How to Apply Silicone Lubricant to the Deck

Step 1: Locate the silicone spray bottle (see the image below in the left), which is included in the treadmill accessory pack.

Step 2: Evenly spray the silicone along the surface of the running deck, as shown in the image below in the right.

1



2

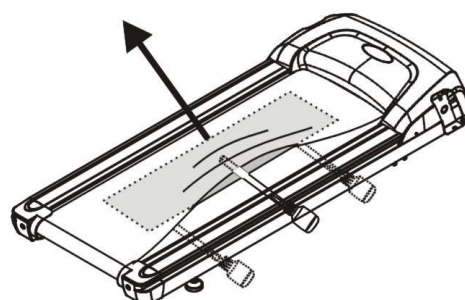

Important Reminder: Always completely stop the tread belt before applying lubricant. Applying silicone while the belt is moving may result in injury, such as cuts from the belt edge or fingers getting caught between the belt and rear roller. Do not over apply silicone, as this may cause the belt to slip during use, affecting both safety and performance.

3.3 Warranty Claim

Please first visit the official website at <https://www.circlefitness.com/support/> to download the service manual as a dealer for troubleshooting. If the issue is not resolved, please go to <http://goo.gl/forms/OplmbWO9kXHJuDYc2> to submit warranty claims. Please provide information as mentioned below and upload your pictures/video clips. Automatic confirmation email will be sent out via warranty.claim259@gmail.com so please make sure this email address is not blocked by your server or email software.

- Vendor's code
- Your email address
- Your name
- Your phone number
- Model description: Please refer to the "Model" field on the equipment label and enter the appropriate model, such as M8, M8 EPlus, M8S, M8T, E8, E8T, E8S, E8 EPlus, B8, B8 EPlus, B8T, or B8S. Only one model can be submitted at a time.
- Serial Number: Please refer to the "Serial Number" field on the equipment label. The serial number consists of one letter followed by nine digits. The first letter represents the equipment type: **T** for treadmills, **E** for elliptical trainers, **R** for recumbent bikes, and **B** for upright bikes. The following nine digits include the manufacturing year and month as part of the serial sequence. You may fill in multiple serial numbers if you submit a warranty claim for the same model.

- Problem description:

Example 1: Incline window showed "Err". All functions of the treadmill are normal except the lift motor. Our engineer has made diagnostics according to the document "Engineering Manual - Trouble Shooting". Also there is a loud noise while pressing the "UP" button. So, he considers the lift motor to be faulty.

Example 2: Display problem: One LED segment is always off.

- Issue solved or not? Solved/ Not solved yet/ others
- Requested Part Name/Number
- Link to the Folder of Pictures/Video Clips: Photos of **warranty labels** are essential for warranty claims on electronics like console, lift motor, inverter, generators and etc.
- End Customer Site Description and Contact
- Reported Failure Date
- Preferred Shipping Method
- Comments: Please leave comments for this issue here if you have any.



circle
FITNESS

ALWAYS MOVING FORWARD



www.circlefitness.com